

SIS3302 14xx Firmware - Gamma

User Manual

SIS GmbH
Harksheider Str. 102A
22399 Hamburg
Germany

Phone: ++49 (0) 40 60 87 305 0
Fax: ++49 (0) 40 60 87 305 20

email: info@struck.de
<http://www.struck.de>

Version: sis3302-M-1408-1-V132-gamma.doc as of 04.12.2009

Revision Table:

Revision	Date	Modification
0.01	27.11.07	Generation from SIS9300 Gamma
1.00	21.01.08	First official release
1.01	12.02.08	Add VME Addressing
1.02	29.07.08	Design Version: 1203 New Clock source: Second internal 100 MHz
1.03	07.11.08	Extend 0x410 key explanation
1.04	12.11.08	Change in Gamma logic block diagram, bug fixes
1.05	16.03.09	Design Version: 1205 - add Next Neighbor Trigger feature - add external Veto/Gate - add internal Trigger or Gate mode - Acquisition control register: add new bits
1.10	18.05.09	Design Version: 1405 - Add MCA Mode - Fir Filter maximum Peaking time and Gap time values expanded from 16 x clock to 64 x clock
1.11	29.05.09	Change in documentation
1.12	10.07.09	Bug fix in broadcast setup
1.20	02.09.09	Design Version: 1406 - Fir Filter maximum Peaking time and Gap time values expanded from 64 x clock to 1023 x clock and add Decimation of 2, 4 or 8 - Energy Filter maximum Peaking time value expanded from 255 x clock to 1023 x clock - maximum Raw Data sample length expanded from 1024 samples to 65532 samples - maximum Pretrigger Delay expanded from 511 clocks to 1023 clocks - maximum Trigger Gate length expanded from 1024 clocks to 65536 clocks - maximum Energy Gate length expanded from 1024 clocks to 131072 clocks - maximum Energy Sample Start Index X values expanded from 1023 to 65535 - maximum Trigger Output Pulse length expanded from 63 clocks to 255 clocks - changed Trigger/Gate logic <ul style="list-style-type: none"> • add Event Extended Configuration registers • add Trigger Extended Setup registers

1.30	11.09.09	Design Version: F407 - add adc value histogramming in MCA Mode <ul style="list-style-type: none">• add ADCx Trigger-50KHz Enable bits in Event Extended configuration registers• add MCA ADCx histogramming Enable bits in MCA Histogram Parameter registers
1.31	28.09.09	Design Version: 1407 - Timestamp-freeze logic modified
1.32	04.12.09	Design Version: 1408 - change Fir Trigger Filter <ul style="list-style-type: none">• reduced maximum Peaking time and Gap time values to 511 clocks• expanded decimation: 1/2/4/8/16• add Trigger Extended Threshold registers

1 Table of contents

1	TABLE OF CONTENTS	4
2	INTRODUCTION.....	7
2.1	FUNCTIONALITY.....	8
2.2	GAMMA LOGIC IMPLEMENTATION	9
2.2.1	<i>General block diagram of one ADC channel and the full module.....</i>	9
2.2.2	<i>Trapezoidal Trigger Filter (Fast FIR Filter).....</i>	10
2.2.2.1	Block diagram of the Trigger MAW unit.....	11
2.2.2.2	Signal diagram of the Trigger MAW unit.....	12
2.2.3	<i>Trapezoidal Energy Filter (Slow FIR Filter).....</i>	12
2.2.3.1	Slow FIR Filter Energy sample logic.....	12
2.2.3.2	Block diagram of the MAWD unit	13
2.2.3.3	Signal diagram of the MAWD unit	13
2.2.3.4	Block diagram of the moving average (MA) unit.....	14
2.2.3.5	Block diagram of the Deconvolution (Tau correction) unit.....	14
2.2.4	<i>Gamma Logic Parameter illustration.....</i>	15
2.2.5	<i>Trigger/Gate logic</i>	17
2.2.6	<i>Next Neighbor Trigger/Gate logic</i>	19
2.2.7	<i>Sample Logic (with MCA Mode = 0).....</i>	21
2.2.7.1	Deadtime	22
2.2.8	<i>MCA Mode</i>	23
2.2.8.1	MCA Scan Enable.....	23
2.2.8.2	MCA Scan Arm	23
2.2.8.3	MCA Multiscan Arm Scan Enable.....	24
2.2.8.4	MCA Multiscan Arm Scan Arm.....	24
2.2.9	<i>CVI plots.....</i>	25
2.2.9.1	Sampling and Energy Filter Parameter screenshot	25
2.2.9.2	Raw signal screenshot	25
2.2.9.3	Raw signal with Pileup screenshot	26
2.2.9.4	Energy Filter data without Tau correction (MAW) screenshot.....	26
2.2.9.5	Energy Filter data with Tau correction (MAWD) screenshot.....	27
3	VME ADDRESSING.....	28
3.1	ADDRESS MAP	29
4	REGISTER/RESOURCE DESCRIPTION	32
4.1	CONTROL/STATUS REGISTER.....	32
4.2	MODULE ID. AND FIRMWARE REVISION REGISTER	33
4.2.1	<i>Major revision numbers</i>	33
4.3	INTERRUPT CONFIGURATION REGISTER	34
4.3.1	<i>IRQ mode.....</i>	34
4.4	INTERRUPT CONTROL REGISTER	35
4.5	ACQUISITION CONTROL REGISTER	36
4.6	BROADCAST SETUP REGISTER	40
4.7	ADC MEMORY PAGE REGISTER	42
4.8	DAC CONTROL REGISTERS.....	43
4.8.1	<i>DAC Control/Status register (read/write).....</i>	43
4.8.2	<i>DAC Data register</i>	44
4.8.3	<i>DAC load sequence.....</i>	44
4.9	MCA SCAN NOF HISTOGRAMS PRESET REGISTER	46
4.10	MCA SCAN HISTOGRAM COUNTER REGISTER	46
4.11	MCA SCAN LNE SETUP AND PRESCALER FACTOR REGISTER	46
4.12	MCA SCAN CONTROL REGISTER	47
4.13	MCA MULTISCAN NOF SCANS PRESET REGISTER.....	48
4.14	MCA MULTISCAN SCAN COUNTER REGISTER	48
4.15	MCA MULTISCAN LAST SCAN HISTOGRAM COUNTER REGISTER	48
4.16	KEY ADDRESS GENERAL RESET (0x400)	49

4.17	KEY ADDRESS SAMPLE LOGIC RESET (0x404).....	49
4.18	KEY ADDRESSES WITH MCA MODE = 0	49
4.18.1	Key address Sample Logic reset (0x410).....	49
4.18.2	Key address VME Disarm Sample logic (0x414).....	49
4.18.3	Key address VME Trigger (0x418)	49
4.18.4	Key address Timestamp Clear (0x41C).....	49
4.18.5	Key address Disarm Sample Logic and Arm sampling on Bank 1 (0x420).....	50
4.18.6	Key address Disarm Sample Logic and Arm sampling on Bank 2 (0x424).....	50
4.19	KEY ADDRESSES WITH MCA MODE = 1	50
4.19.1	Key address MCA Scan LNE pulse (0x410).....	50
4.19.2	Key address MCA Scan Operation Arm (0x414).....	50
4.19.3	Key address MCA Scan Enable (0x418)	51
4.19.4	Key address MCA Scan Disable (0x41C).....	51
4.19.5	Key address MCA Multiscan Start/Reset pulse (0x420).....	51
4.19.6	Key address MCA Multiscan Arm with Scan operation Arm (0x424)	51
4.19.7	Key address MCA Multiscan Arm with Scan operation Enable (0x428).....	51
4.19.8	Key address MCA Multiscan Disable (0x42C).....	51
4.20	EVENT CONFIGURATION REGISTERS.....	52
4.21	EVENT EXTENDED CONFIGURATION REGISTERS	53
4.22	END ADDRESS THRESHOLD REGISTERS.....	54
4.23	PRETRIGGER DELAY AND TRIGGER GATE LENGTH REGISTERS.....	55
4.24	RAW DATA BUFFER CONFIGURATION REGISTERS	56
4.25	ADC1-8 NEXT SAMPLE ADDRESS REGISTER	57
4.26	ADC1-8 PREVIOUS BANK SAMPLE ADDRESS REGISTER.....	57
4.27	ACTUAL SAMPLE REGISTERS.....	58
4.28	TRIGGER SETUP REGISTERS.....	59
4.29	TRIGGER EXTENDED SETUP REGISTERS	60
4.30	TRIGGER THRESHOLD REGISTERS.....	62
4.30.1	Extended Threshold Mode = 0.....	63
4.30.2	Extended Threshold Mode = 1.....	63
4.30.3	Trigger example	64
4.31	TRIGGER EXTENDED THRESHOLD REGISTERS	66
4.32	ENERGY SETUP GP REGISTERS.....	67
4.33	ENERGY GATE LENGTH REGISTERS	68
4.34	ENERGY SAMPLE REGISTERS.....	68
4.34.1	Energy Sample Length registers	69
4.34.2	Energy Sample Start Index1 registers	69
4.34.3	Energy Sample Start Index2 registers	69
4.34.4	Energy Sample Start Index3 registers	69
4.35	ENERGY TAU FACTOR REGISTERS	70
4.36	MCA ENERGY_TO_HISTOGRAM CALCULATION PARAMETER REGISTER.....	72
4.37	MCA HISTOGRAM PARAMETER REGISTER.....	74
4.38	MCA TRIGGER START COUNTER REGISTER	75
4.39	MCA PILEUP COUNTER REGISTER	75
4.40	MCA ENERGY_TO_HIGH COUNTER REGISTER.....	76
4.41	MCA ENERGY_TO_LOW COUNTER REGISTER	76
4.42	ADC MEMORY	77
4.42.1	Event Buffer Data Format (with MCA Mode = 0).....	77
5	MODES OF ACQUISITION OF CURRENT SOFTWARE.....	80
5.1	SINGLE EVENT ACQUISITION	80
5.2	MULTI EVENT DOUBLE BUFFER ACQUISITION.....	80
6	BOARD LAYOUT	81
7	FRONT PANEL.....	82
7.1	CONTROL IN/OUTPUTS	83
7.2	LED'S.....	84
7.3	CHANNEL LED'S	84

7.4	PCB LEDs.....	84
8	JUMPERS/CONFIGURATION	85
8.1	CON100 JTAG.....	85
8.2	JP80 VME ADDRESSING MODE/RESET BEHAVIOUR	85
8.3	JP101 JTAG CHAIN	86
8.4	JP102 JTAG SOURCE.....	87
8.5	JP120A-JP120D CONTROL INPUT TERMINATION.....	88
8.6	SW1 AND SW2, VME BASE ADDRESS	88
9	SOFTWARE/GETTING STARTED.....	89
9.1	HEADER FILES	89
9.2	C CODE	90
10	APPENDIX.....	91
10.1	POWER CONSUMPTION.....	91
10.2	OPERATING CONDITIONS.....	91
10.2.1	<i>Cooling.....</i>	<i>91</i>
10.2.2	<i>Hot swap/live insertion.....</i>	<i>91</i>
10.3	CONNECTOR TYPES.....	92
10.4	P2 ROW A/C PIN ASSIGNMENTS	92
10.5	ROW D AND Z PIN ASSIGNMENTS.....	93
10.6	FIRMWARE UPGRADE.....	94
10.6.1	<i>Upgrade over CON100.....</i>	<i>94</i>
10.6.2	<i>Upgrade over VME.....</i>	<i>94</i>
11	INDEX.....	95

2 Introduction

This firmware manual/addendum describes the functionality and implementation of the SIS3302 firmware major revision 0x14. Besides finite response filter (FIR) based triggering this version supports asynchronous readout of a programmable set of features of raw (i.e. digitized wave form) and/or computed (like signal height/energy e.g.) digitizer information. No hardware modification to the SIS3302 is required for installation of this firmware. This firmware implementation should be of particular interest for detector studies with Gamma ray tracking and strip detectors.

2.1 Functionality

The main functions of the firmware are listed below and illustrated in the Gamma logic block diagram.

- 8 channel asynchronous and synchronous operation
- Decimation
- Trapezoidal Energy filter
- Trigger FIR filter
- Trigger or output

- 48-bit Timestamp
- Flexible event storage

- MCA Histogramming in the ADC Memory

2.2 Gamma Logic Implementation

2.2.1 General block diagram of one ADC channel and the full module

SIS3302-Gamma V_1406

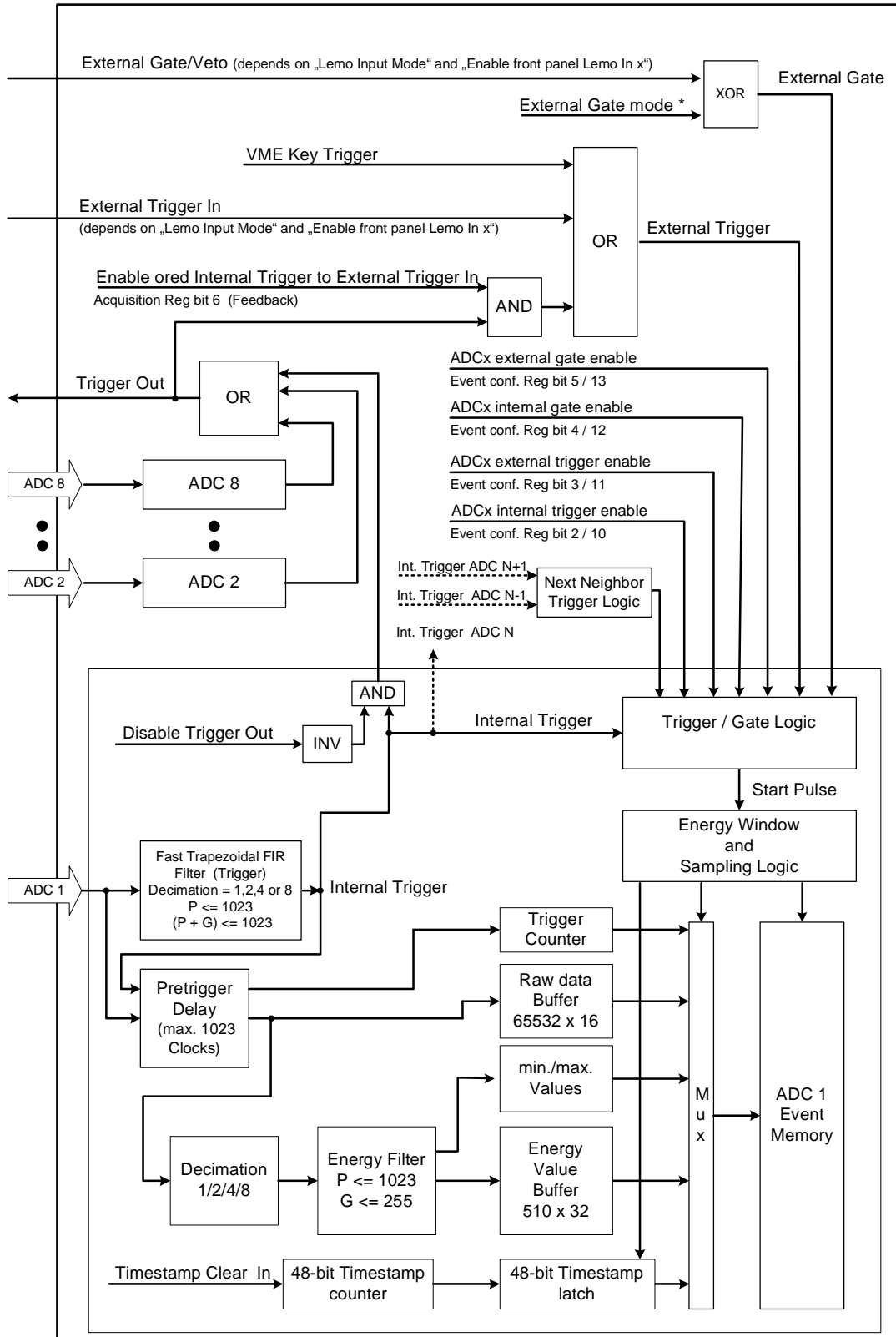

2.2.2 Trapezoidal Trigger Filter (Fast FIR Filter)

A trapezoidal FIR filter is implemented for each ADC Channel to generate a trigger signal. This Trigger Signal can be used to trigger the sample logic immediately or it can be routed to SIS3302 Lemo Output.

This Trigger Signal will be also used to store the “Fast Filter trigger” information.

Features for each ADC channel:

- Programmable decimation (1 / 2 / 4 / 8 / 16 Clocks)
- Programmable Peaking Time (max. 511 Clocks)
- Programmable SumGap Time (max. 511 Clocks)
- Programmable Trigger pulse out length (max. 255 Clocks)
- Programmable Trigger Threshold
- Programmable Trigger Extended Threshold (finer granularity)
- Programmable Trigger Mode (GT,Disable)
- Programmable Trigger OUT (Enable,Disable)

see Trigger Setup ADCx registers, Trigger Extended Setup ADCx registers, Trigger Threshold ADCx registers and Trigger Extended Threshold ADCx registers.

2.2.2.1 Block diagram of the Trigger MAW unit

Explanation:

- MAW: moving average window
- MA: moving average
- Decimation: decreasing the clock rate
- Peaking Time: the length of the MA for moving average unit
- SumGap Time: the differentiation time of the moving window average unit

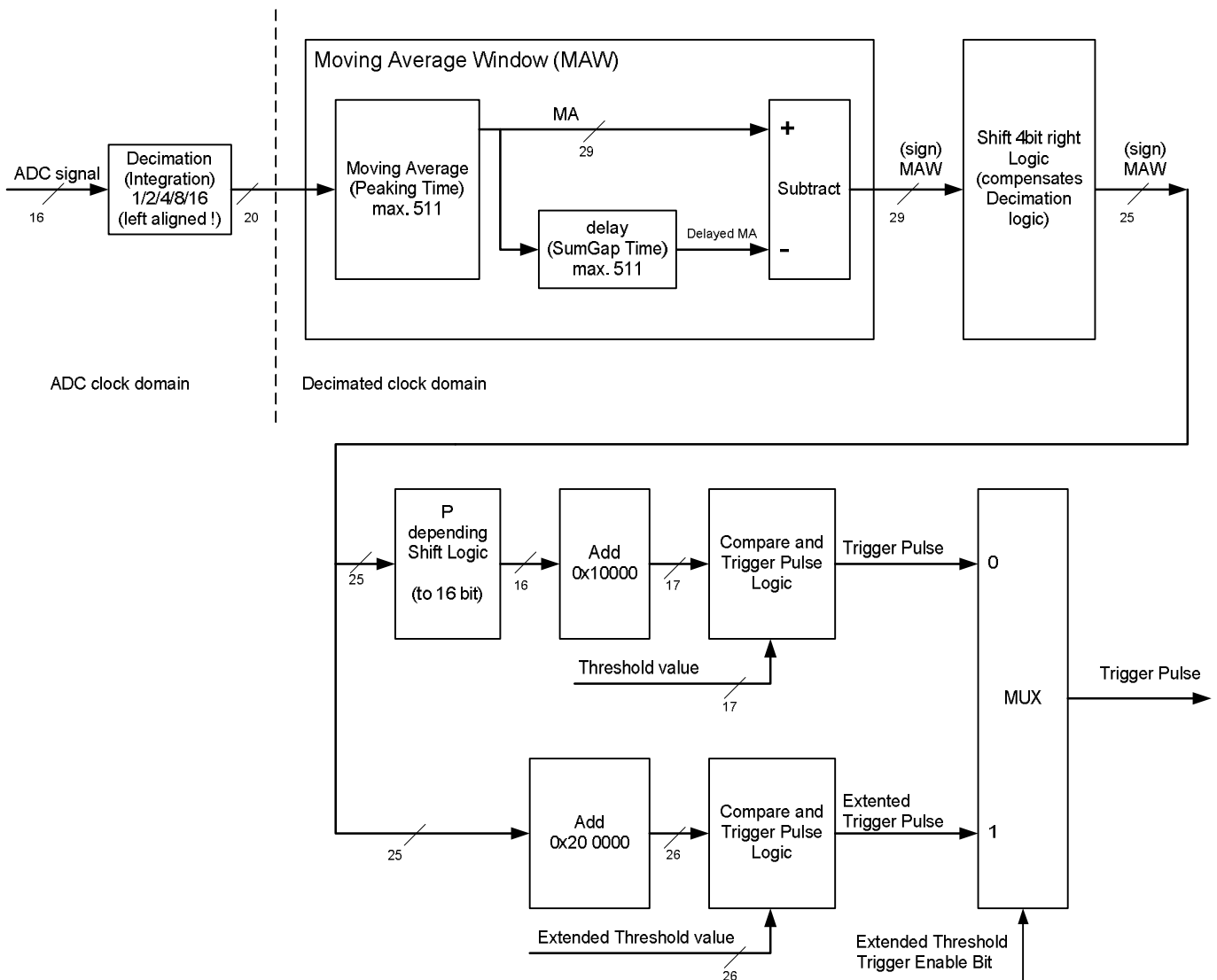

2.2.2.2 Signal diagram of the Trigger MAW unit

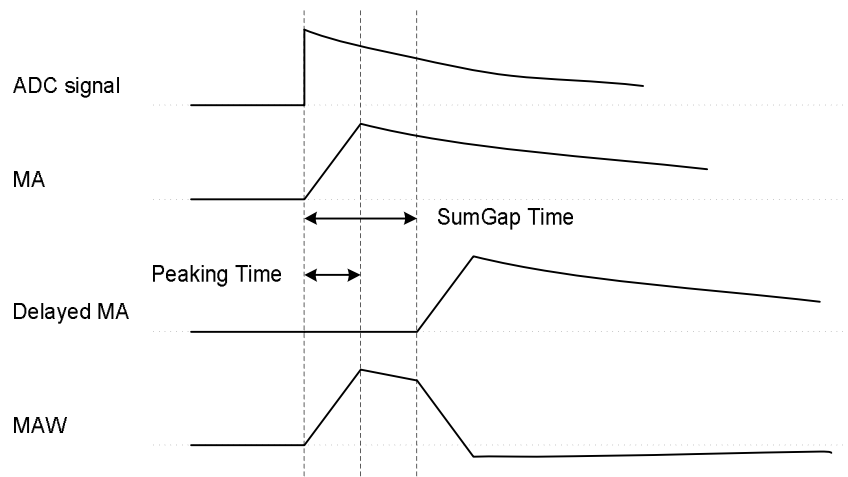

2.2.3 Trapezoidal Energy Filter (Slow FIR Filter)

A trapezoidal FIR filter is implemented for each ADC Channel to generate a “moving window average” stream (MWA) .

A decimation logic (average, integration) is also implemented.

Features of the Slow FIR Filter:

- Programmable decimation (1 / 2 / 4 / 8 Clocks)
- Programmable Peaking Time (max. 1023 Clocks)
- Programmable Gap Time (max. 255 Clocks)

2.2.3.1 Slow FIR Filter Energy sample logic

Five registers are implemented to control the sampling of the MWD.

- Energy Gate Length
- Energy Sample Length register
- Energy Sample Start Index1 register
- Energy Sample Start Index2 register
- Energy Sample Start Index3 register

The “Slow FIR Filter Energy sample” logic starts with the Energy Gate and executes following steps:

1. Clears an internal Energy Index counter and starts this Index counter.
The logic is busy until the Index counter reaches the value of the Energy Gate Length register (busy with the Energy Gate).
2. Compares the Index counter with the Energy Sample Start Index x registers.
If the result is equal the logic writes N (Energy Sample Length register) values into the Energy Buffer.
3. The logic saves the Energy at the beginning of the Energy Gate.
4. The logic saves the maximum Energy inside the Energy Gate.

2.2.3.2 Block diagram of the MAWD unit

Explanation:

- MAWD: moving average window deconvolution (Tau correction)
- MAW: moving average window
- MA: moving average
- Decimation: decreasing the clock rate
- Peaking Time: the length of the MA for moving average unit
- Gap Time: the differentiation time of the moving window average unit plus the Peaking time (Flat)

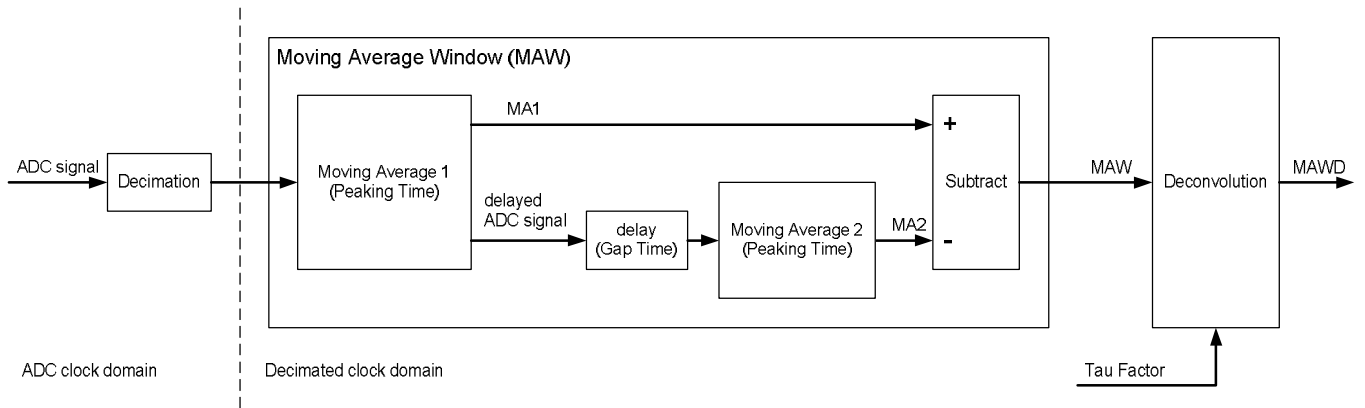

2.2.3.3 Signal diagram of the MAWD unit

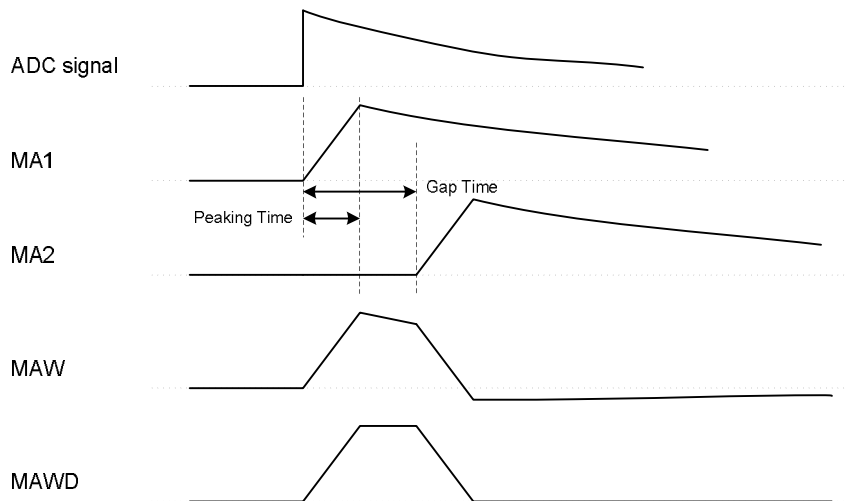

2.2.3.4 Block diagram of the moving average (MA) unit

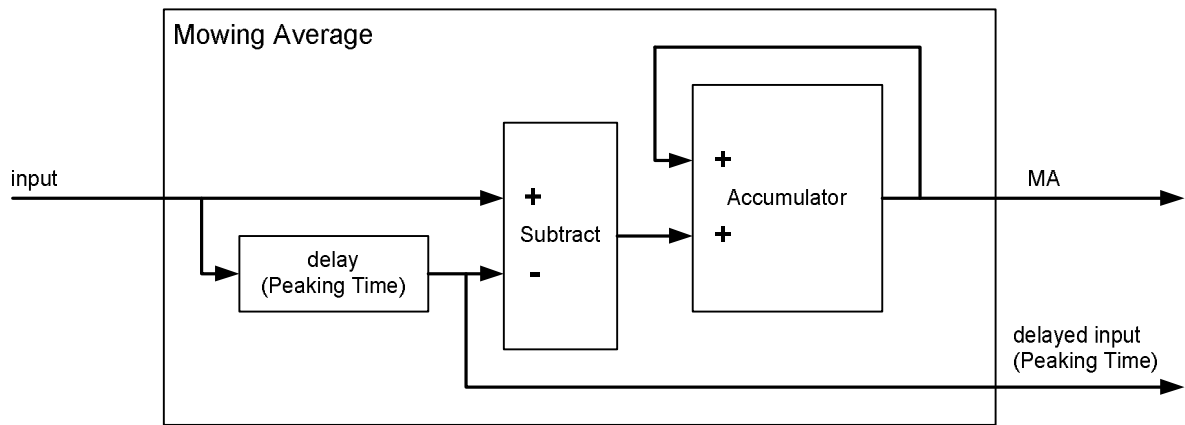

2.2.3.5 Block diagram of the Deconvolution (Tau correction) unit

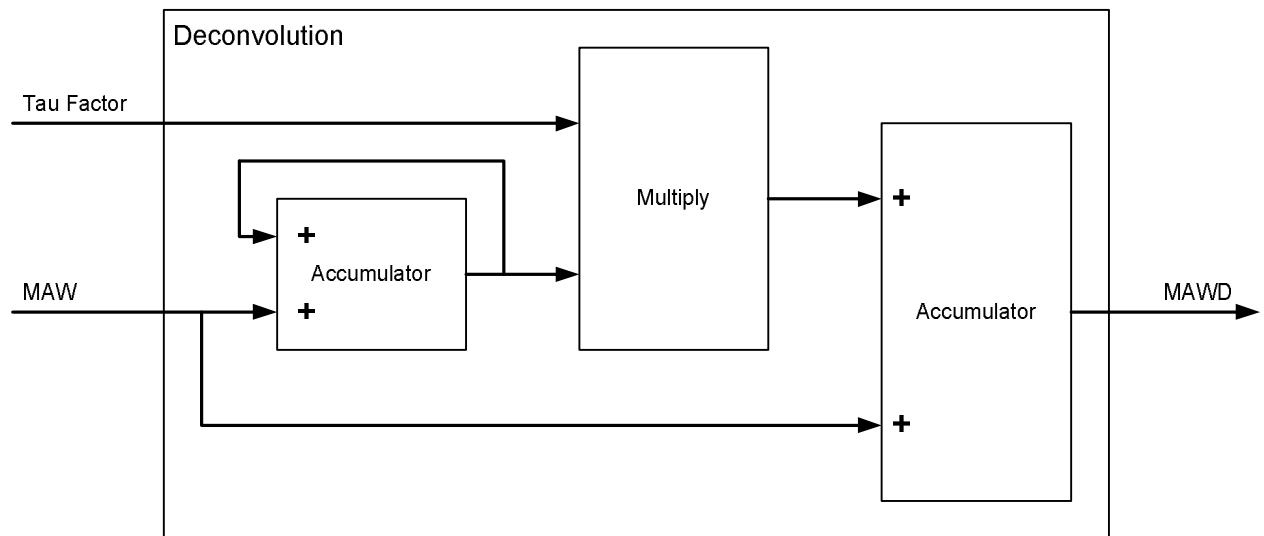

2.2.4 Gamma Logic Parameter illustration

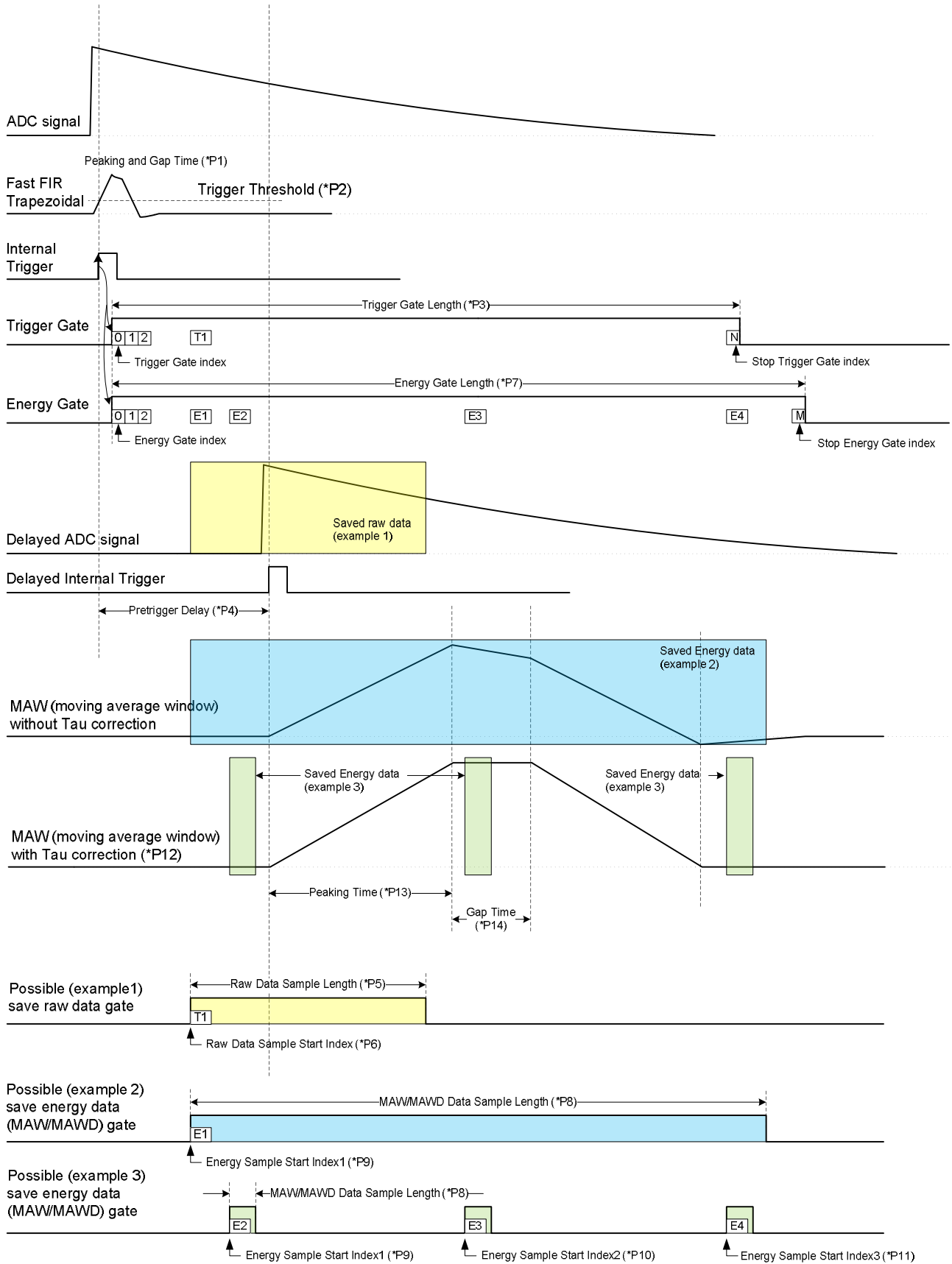

The Gamma Logic parameters are:

- *P1: Fast FIR Filter (Trigger) parameters: see Trigger Setup ADCx registers
- *P2: Fast FIR Filter (Trigger) Threshold: see Trigger Threshold ADCx registers

- *P3: Trigger Gate Length: see Pretrigger Delay and Trigger Gate Length registers
- *P4: Pretrigger Delay: see Pretrigger Delay and Trigger Gate Length registers

- *P5: Raw Data Sample Length: see Raw Data Buffer Configuration registers
- *P6: Raw Data Sample Start Index: see Raw Data Buffer Configuration registers

- *P7: Energy Gate Length: see Energy Gate Length registers

- *P8: Energy Sample Length: see Energy Sample Length registers
- *P9: Energy Sample Start Index1: see Energy Sample Start Index1 registers
- *P10: Energy Sample Start Index2: see Energy Sample Start Index2 registers
- *P11: Energy Sample Start Index3: see Energy Sample Start Index3 registers

- *P12: Energy Tau correction Factor: see Tau Factor registers

- *P13: Energy Filter Peaking Time: see Energy Setup GP registers
- *P14: Energy Filter GapTime: see Energy Setup GP registers

2.2.5 Trigger/Gate logic

Trigger / Gate logic illustration:

SIS3302-Gamma V_1406 Trigger/Gate Logic

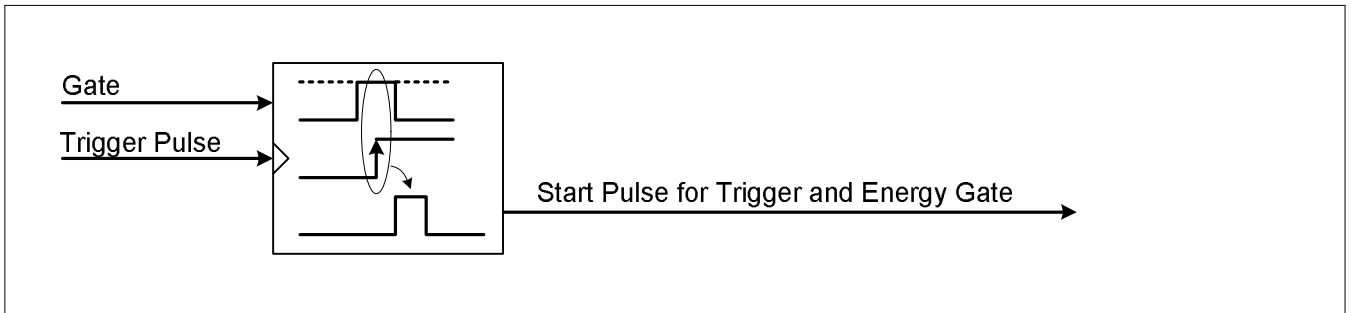
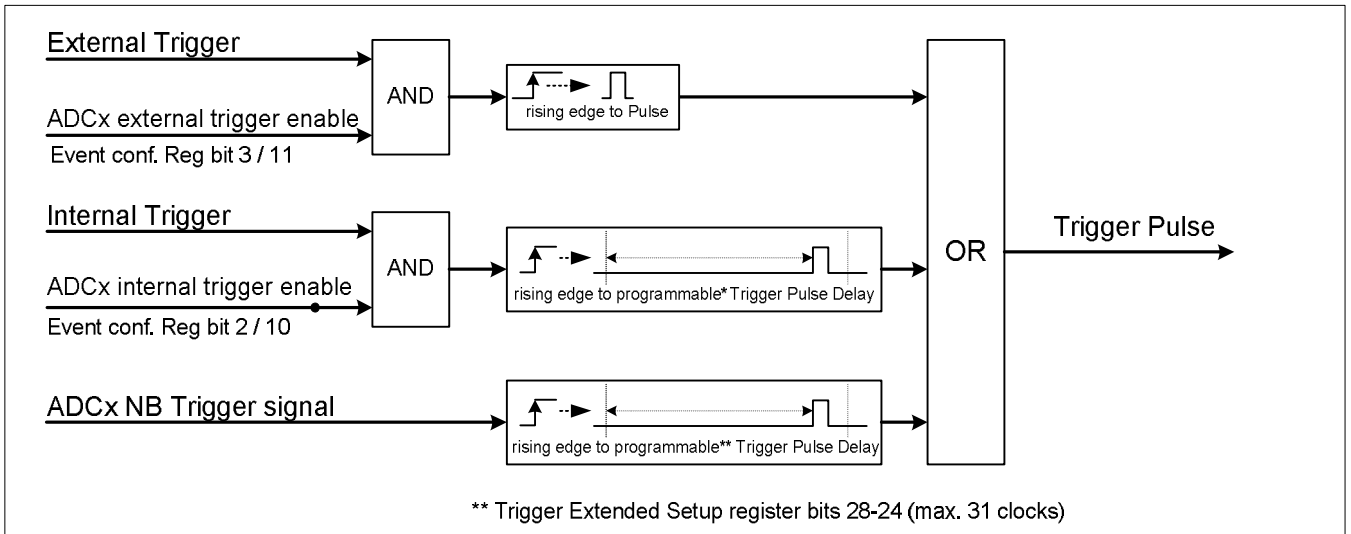
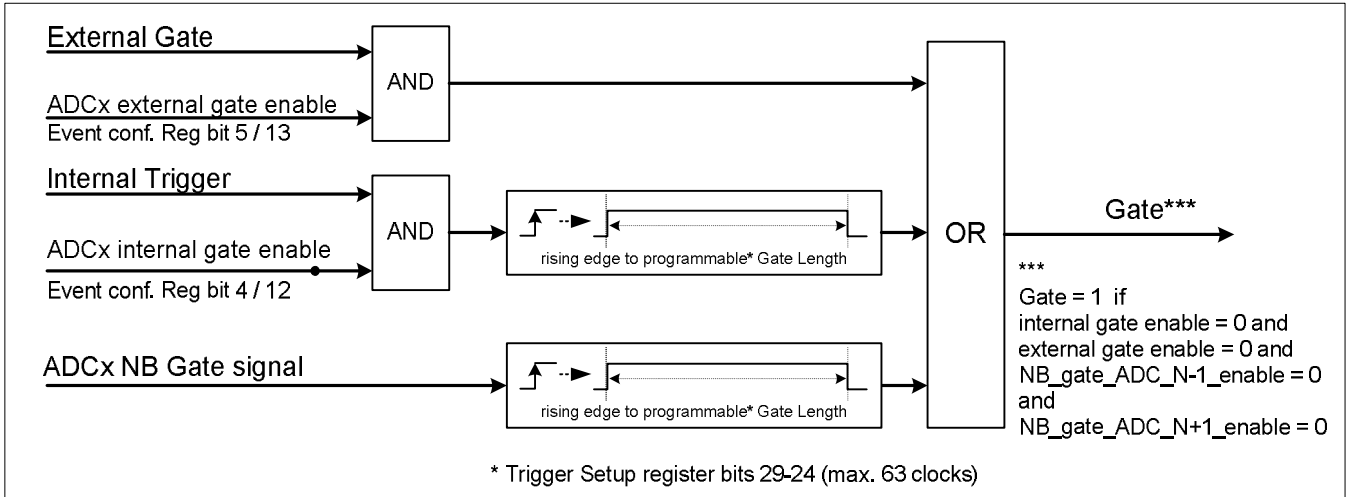

Example1: Internal Trigger / External Gate

- “Lemo Input Mode” = 1 and “Lemo Output Mode” = 0
- Lemo In 1 connected with Lemo Out 1 and “Enable front panel Lemo In 1”= 1
- “ADCx internal trigger enable” = 1 and “ADCx external gate enable” = 1
- “Internal Trigger Pulse Length” = 30
- “**Internal Trigger Delay**/ Internal Gate Length” = 20

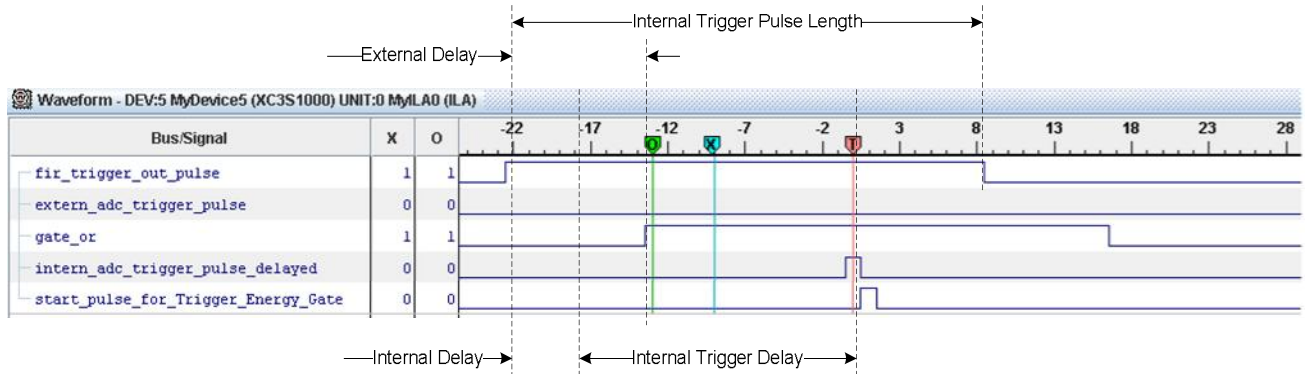

Example 2: External Trigger / Internal Gate

- “Lemo Input Mode” = 0 and “Lemo Output Mode” = 0
- Lemo In 3 connected with Lemo Out 1 and “Enable front panel Lemo In 3”= 1 or “Enable ored Internal Trigger to External Trigger In” = 1 (Feedback)
- “ADCx external trigger enable” = 1 and “ADCx internal gate enable” = 1
- “Internal Trigger Pulse Length” = 6
- “Internal Trigger Delay/ **Internal Gate Length**” = 20

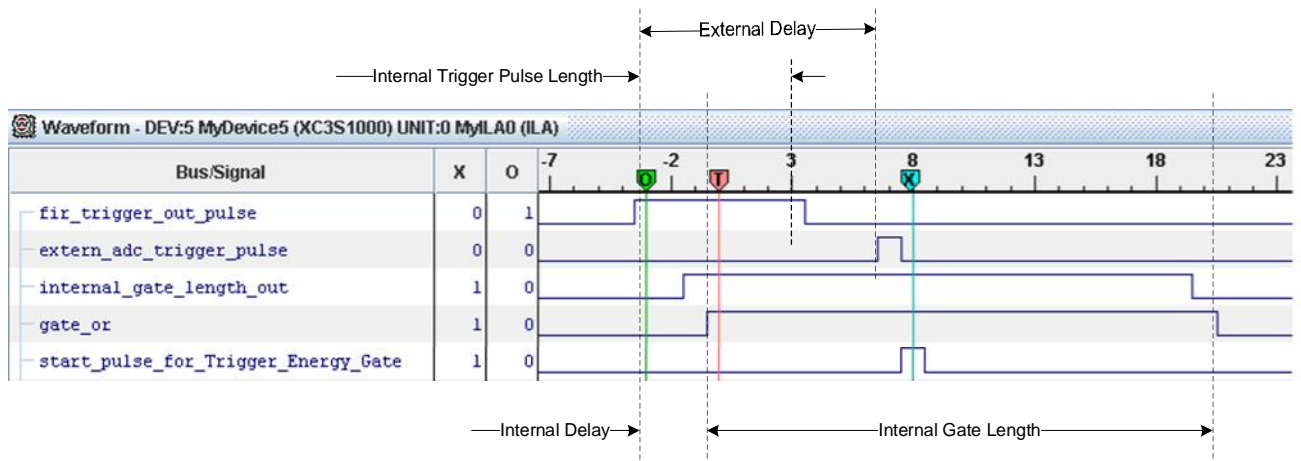

Legend

`fir_trigger_out_pulse`: generated from the internal Fast Fir Filter (internal Trigger) with the programmed Trigger Pulse Length.

Internal Delay: 4 clocks

External Delay: 8 clocks + external Logic (Cable, external user logic)

2.2.6 Next Neighbor Trigger/Gate logic

Next Neighbor Trigger logic illustration:

SIS3302-Gamma V_1406: Next Neighbor Trigger

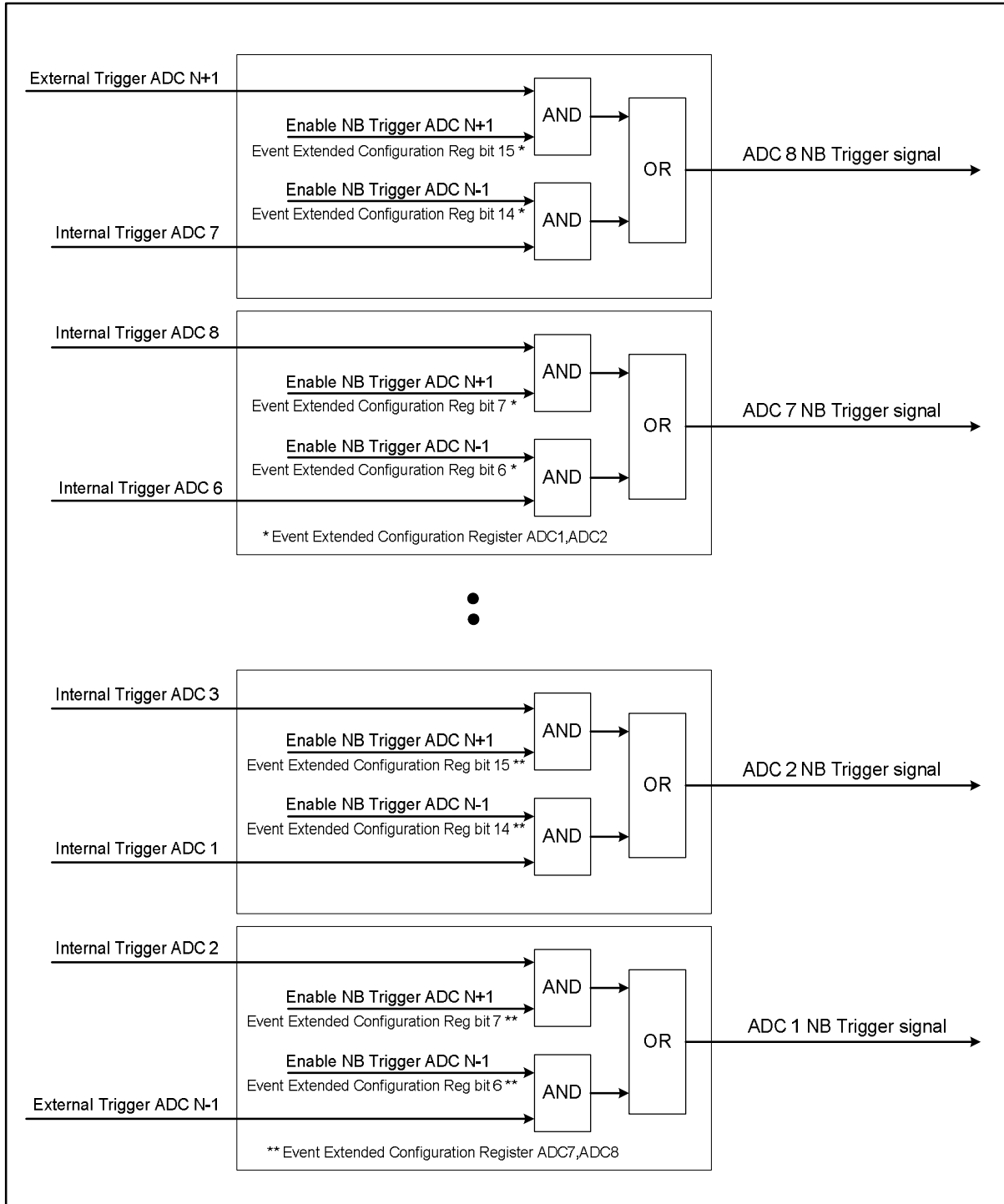

Attention: Next Neighbor Trigger logic is not implemented on the SIS3302 4-channel version.

Next Neighbor Gate logic illustration:

SIS3302-Gamma V_1406: Next Neighbor Gate Logic

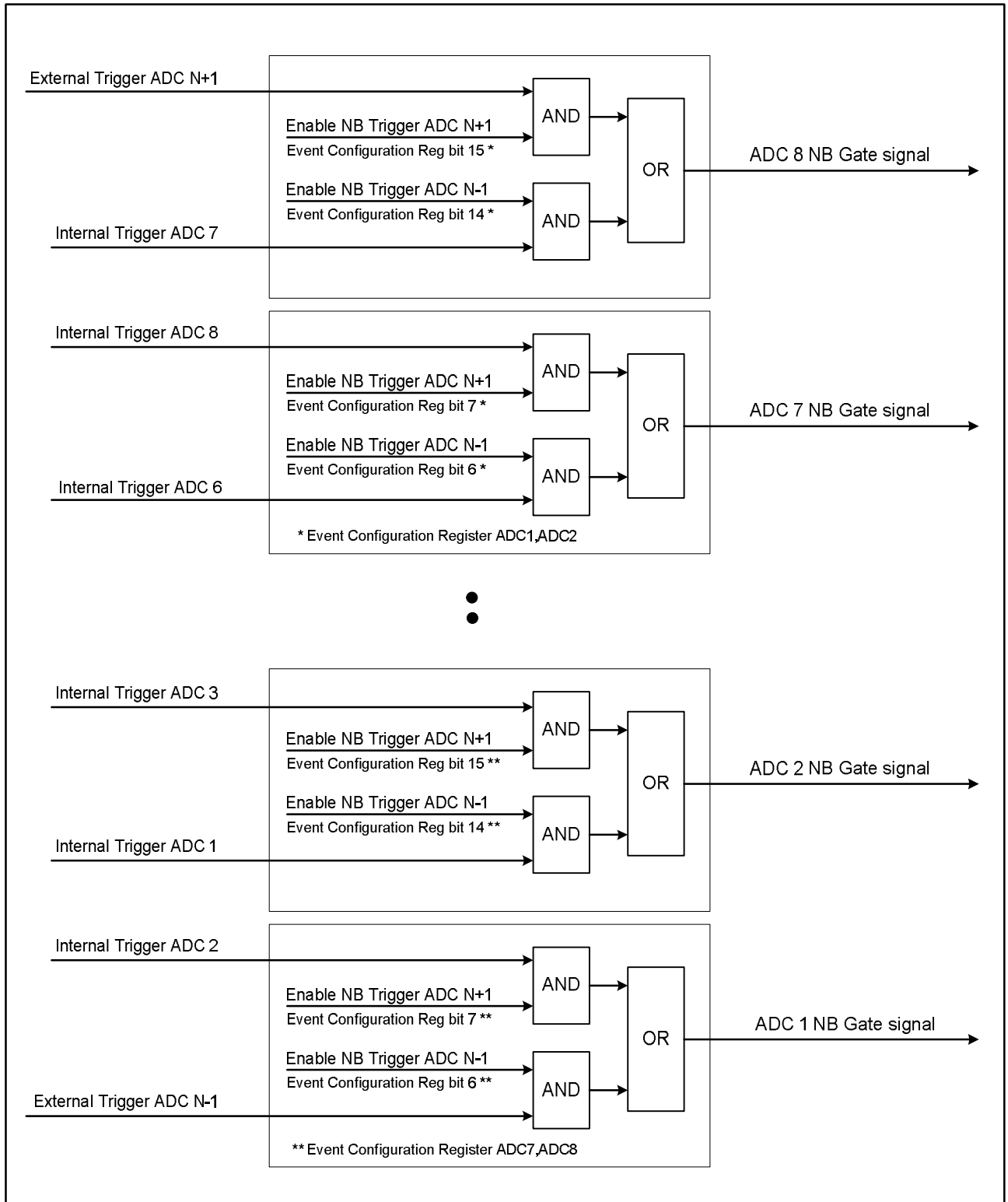

Attention: Next Neighbor Gate logic is not implemented on the SIS3302 4-channel version.

2.2.7 Sample Logic (with MCA Mode = 0)

The sample logic starts with a trigger signal (Start Pulse for Trigger and Energy Gate) and executes following steps:

1. starts the Trigger and Energy Gate and stores the 48-bit timestamp.
2. writes the 16-bit programmable ADC Header and the stored 48-bit Timestamp into the Event Memory.
3. writes a programmable number of ADC Raw Values into the Event Memory.
4. writes at the end of the Energy Gate a programmable number of Slow FIR Values (MAWD) into the Event Memory.
5. writes the maximum and minimum (first value of Energy Gate) MAWD value into the Event Memory.
6. writes the Fast Filter Information register into the Event Memory.
7. writes a Trailer into the Event Memory.

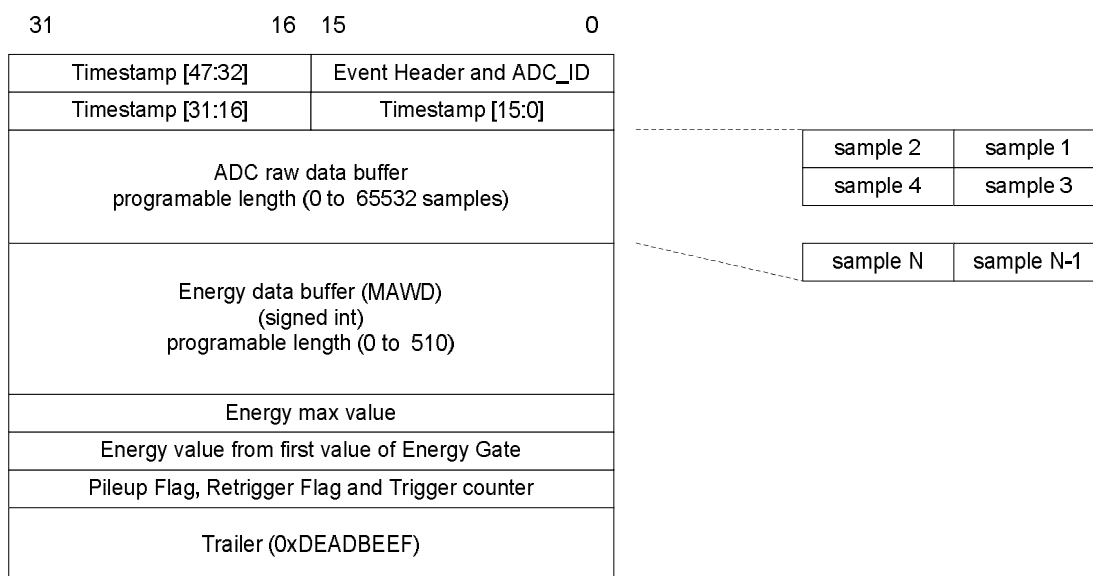

2.2.7.1 Deadtime

Event storage induces Deadtime.

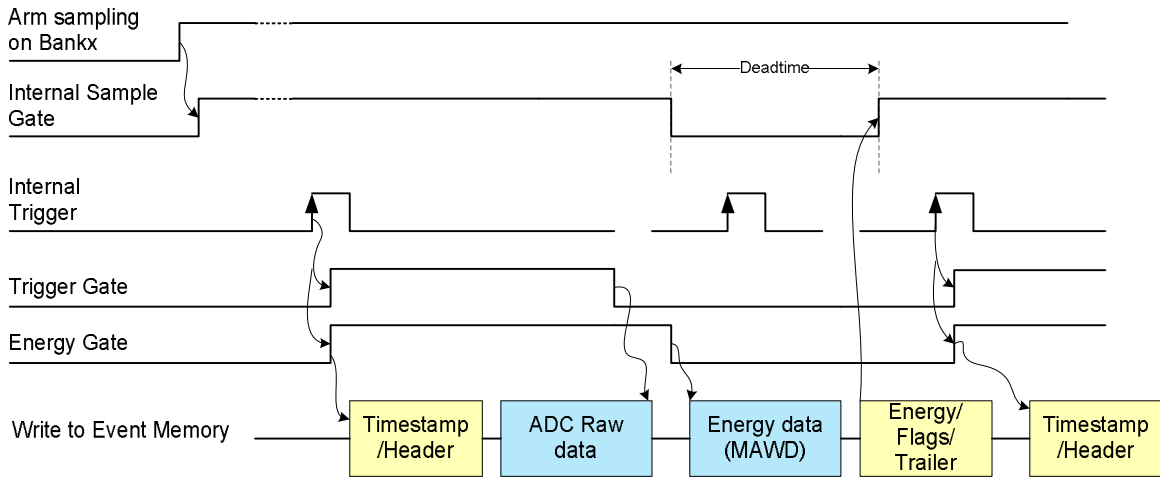

Deadtime table

Raw Data Sample Length	Energy Sample Length	Deadtime (approximate)
0	0	150 ns
100	0	560 ns
500	0	2 us
1000	0	3.9 us
0	12	1 us
100	12	1.2 us
500	12	3 us
1000	12	7 us
0	256	5.4 us
100	256	5.6 us
500	256	8.0 us
1000	256	10.6 us
0	512	9.6 ns
100	512	9.8 us
500	512	10.8 us
1000	512	14 us

2.2.8 MCA Mode

- 1/2/4/8K Histogram Bins (histogram page size)

Page Clear Time table

Page Size	Page Clear Time (approximate)
1K	11 us
2K	22 us
4K	44 us
8K	88 us

2.2.8.1 MCA Scan Enable

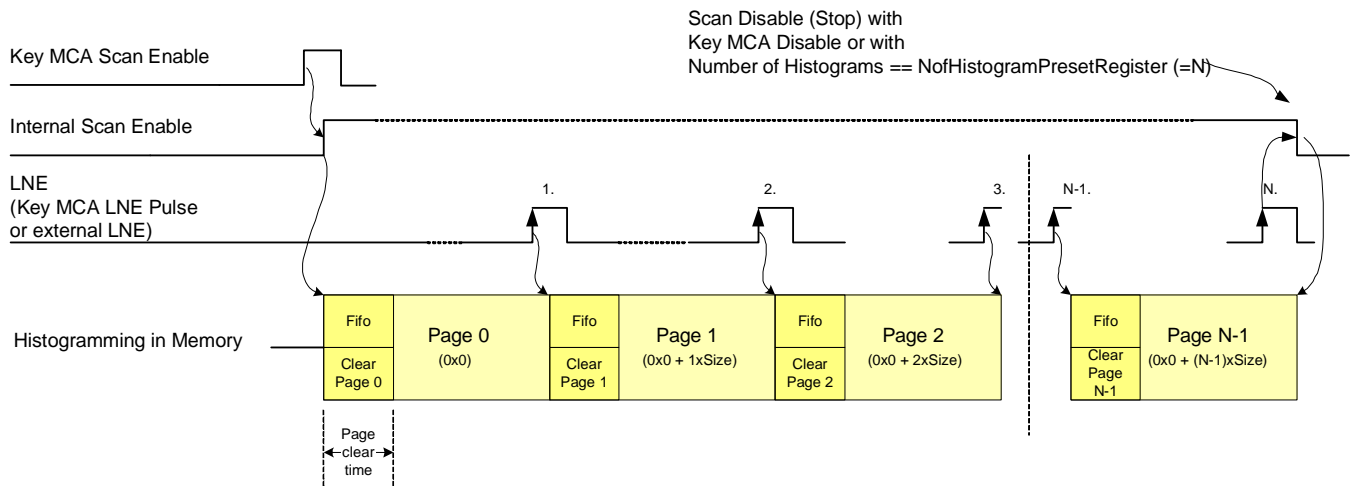

2.2.8.2 MCA Scan Arm

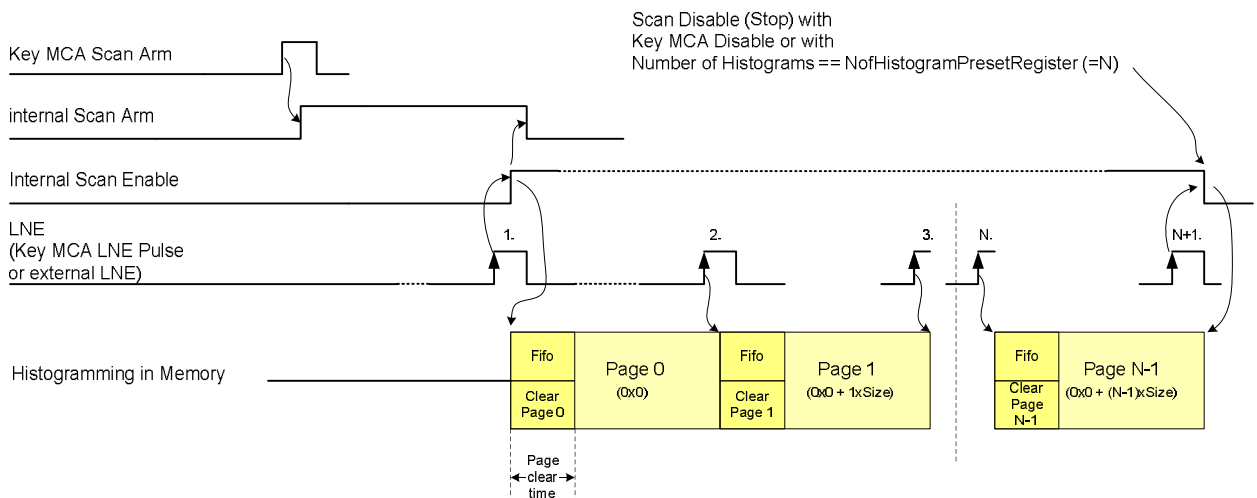

2.2.8.3 MCA Multiscan Arm Scan Enable

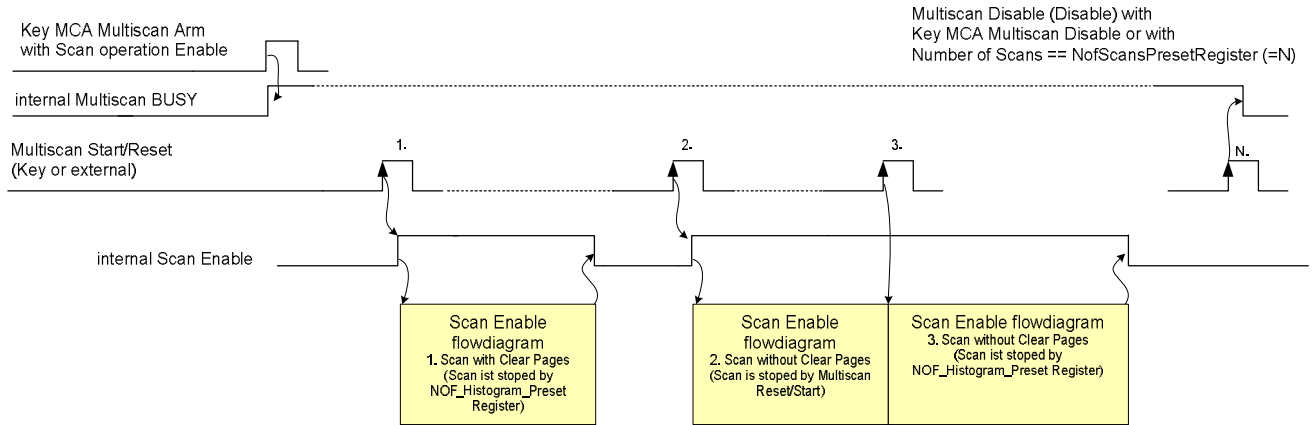

2.2.8.4 MCA Multiscan Arm Scan Arm

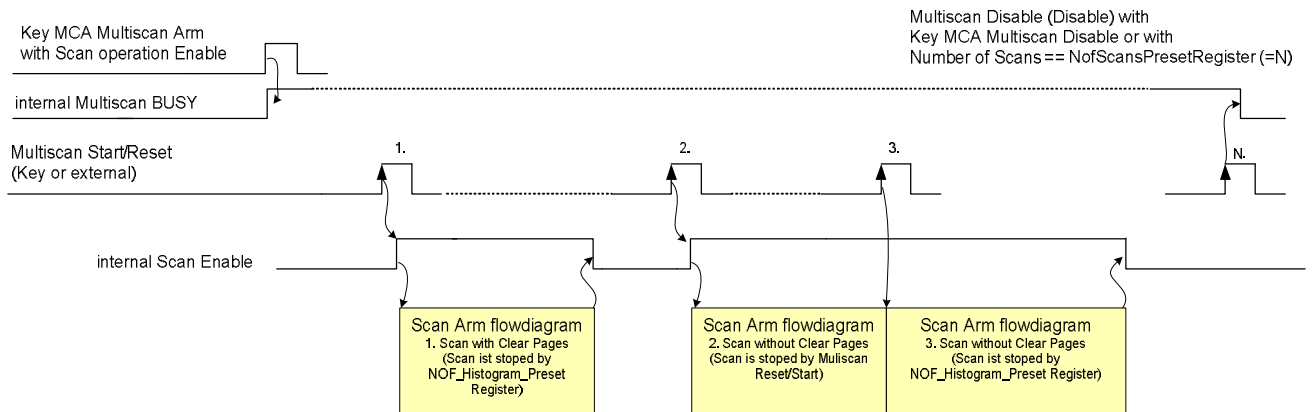

2.2.9 CVI plots

2.2.9.1 Sampling and Energy Filter Parameter screenshot

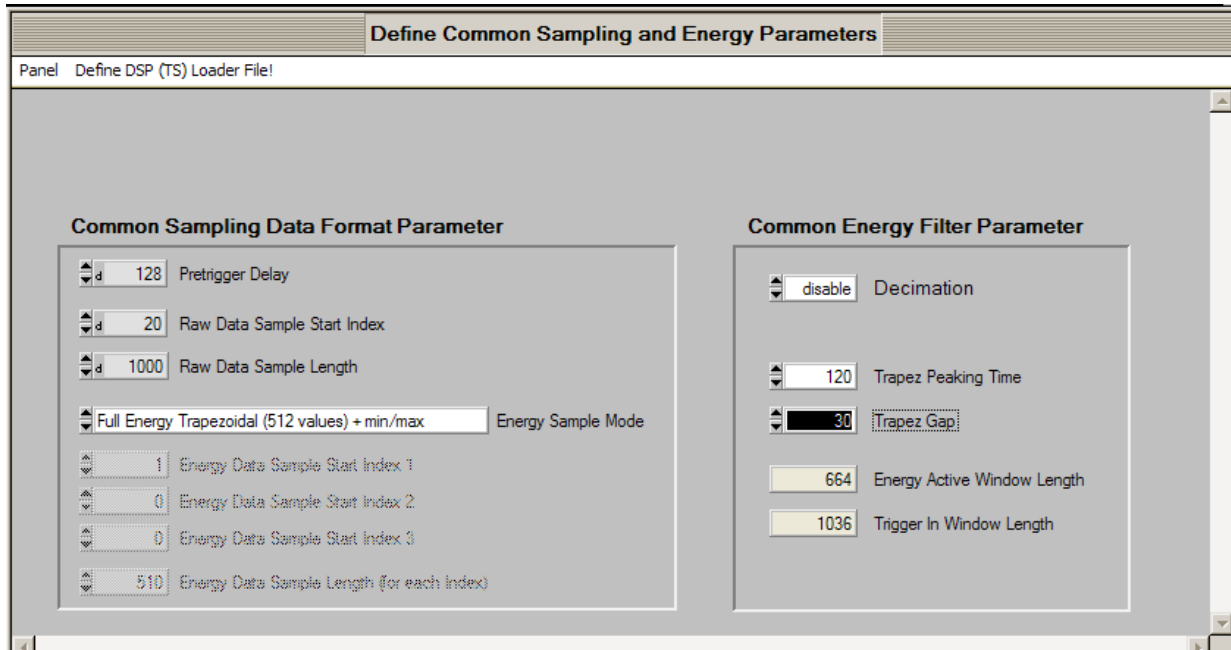

2.2.9.2 Raw signal screenshot

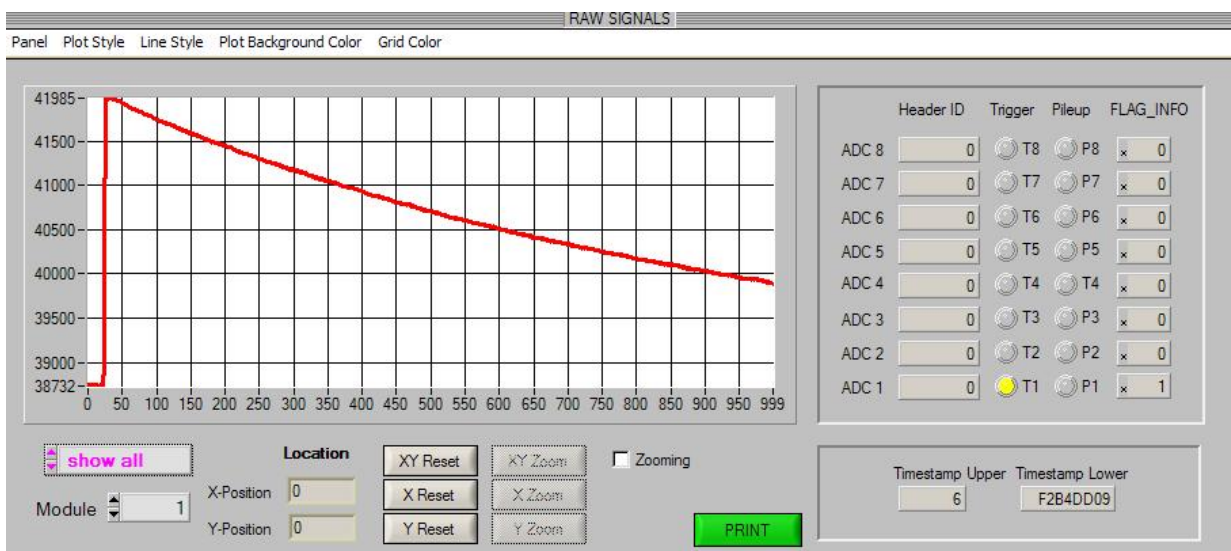

2.2.9.3 Raw signal with Pileup screenshot

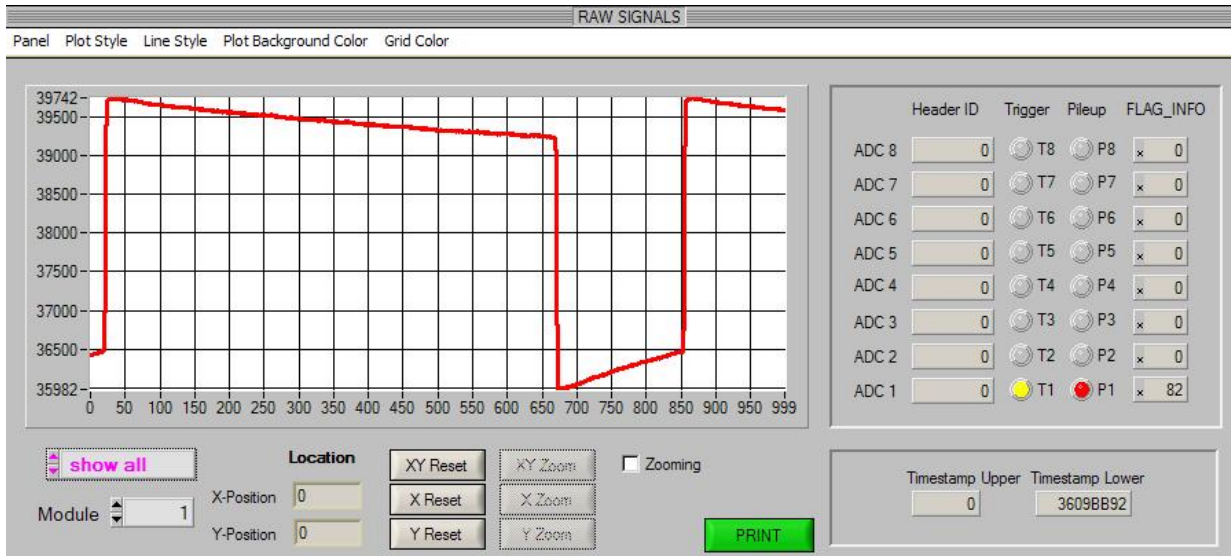

2.2.9.4 Energy Filter data without Tau correction (MAW) screenshot

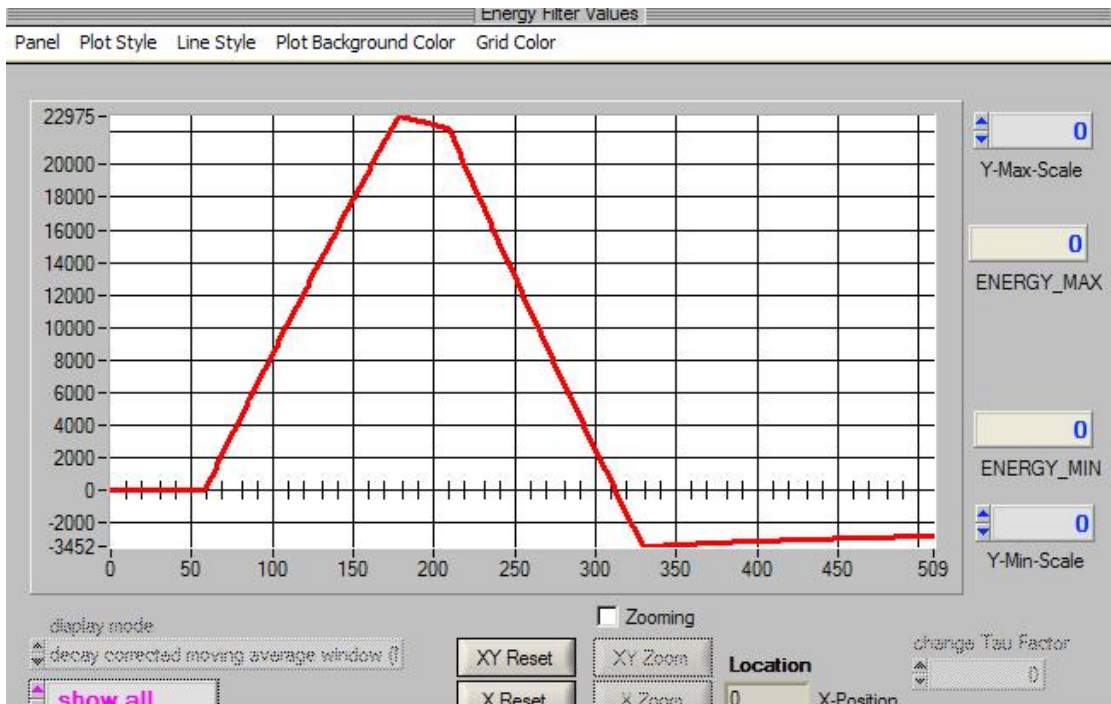

2.2.9.5 Energy Filter data with Tau correction (MAWD) screenshot

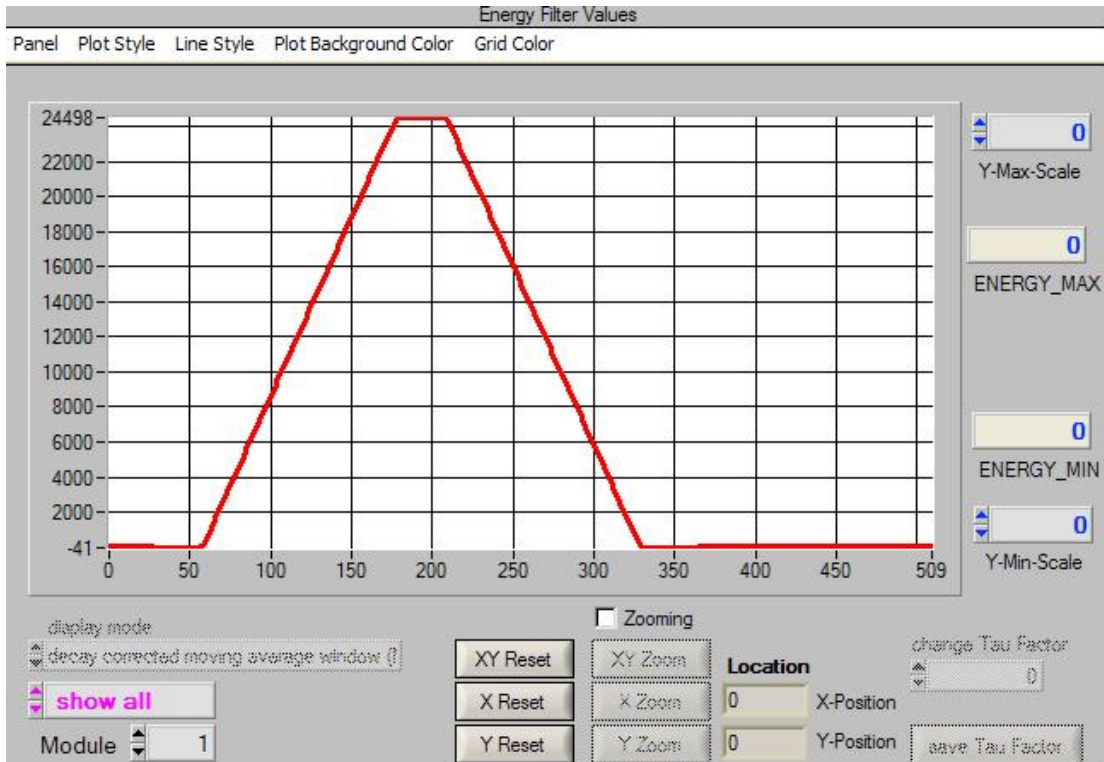

3 VME Addressing

As the SIS3302 VME FADC features memory options with up to 8 times 32 MSamples, A32 addressing was implemented as the only option. The module occupies an address space of 0x7FFFFFFF Bytes, i.e. 128 MBytes are used by the module.

The base address is defined by the selected addressing mode, which is selected by jumper array JP80 and SW1 and SW2 (in non geographical mode).

The table below summarises the possible base address settings.

J1 Setting			Bits				
A32	GEO	VIPA	31	30	29	28	27
x			SW1				SW2=0...7 Bit 27=0
x			SW1				SW2=8...F Bit 27=1
x	x		Not implemented in this design				
		x	Not implemented in this design				

Shorthand	Explanation
SW1/SW2	Setting of rotary switch SW1 or SW2 respective

Notes:

- This concept allows the use of the SIS3302 in standard VME as well as in VME64x environments, i.e. the user does not need to use a VME64x backplane.
- The factory default setting is EN_A32 closed, SW1=3, SW2=0 (i.e. the module will react to A32 addressing under address 0x30000000). With more than one unit shipped in one batch a set of addresses (like 0x10000000, 0x20000000, 0x30000000,...) may be used also.

3.1 Address Map

The 0x120x firmware specific SIS3302 resources and their locations are listed with function in the table below. The header file (sis3302_v1405.h or equivalent) provides the define statements.

Offset	Size in Bytes	BLT	Access	Function
0x00000000	4	-	W/R	Control/Status Register (J-K register)
0x00000004	4	-	R	Module Id. and Firmware Revision register
0x00000008	4	-	R/W	Interrupt configuration register
0x0000000C	4	-	R/W	Interrupt control register
0x00000010	4	-	R/W	Acquisition control/status register (J-K register)
0x00000030	4	-	R/W	Broadcast Setup register
0x00000034	4	-	R/W	ADC Memory Page register
0x00000050	4	-	R/W	DAC Control Status register
0x00000054	4	-	R/W	DAC Data register
0x00000060			R/W	XILINX JTAG_TEST/JTAG_DATA_IN
0x00000064			W	XILINX JTAG_CONTROL
0x00000080			R/W	MCA Scan Nof Histograms preset register
0x00000084			R	MCA Scan Histogram counter register
0x00000088			R/W	MCA Scan LNE Setup and Prescaler Factor register
0x0000008C			R/W	MCA Scan Control register
0x00000090			R/W	MCA Multiscan Nof Scans preset register
0x00000094			R	MCA Multiscan Scan counter register
0x00000098			R	MCA Multiscan last Scan Histogram count register
0x00000400	4	-	KA W	Key address Reset
0x00000404	4	-	KA W	Key address Sample Logic Reset
MCA mode = 0				
0x00000410	4	-	KA W	Key address Sample Logic Reset
0x00000414	4	-	KA W	Key address Disarm Sample Logic
0x00000418	4	-	KA W	Key address Trigger
0x0000041C	4	-	KA W	Key address Timestamp Clear
0x00000420	4		KA W	Key address Disarm Sample Logic and Arm sampling on Bank 1
0x00000424	4		KA W	Key address Disarm Sample Logic and Arm sampling on Bank 2
0x00000428	4	-	KA W	Key address Reset DDR2 Memory Logic
MCA mode = 1				
0x00000410	4	-	KA W	Key MCA Scan LNE Pulse
0x00000414	4	-	KA W	Key MCA Scan operation Arm (start with next LNE)
0x00000418	4	-	KA W	Key MCA Scan Enable (start immediately)
0x0000041C	4	-	KA W	Key MCA Scan Disable
0x00000420	4		KA W	Key MCA Multiscan Start/Reset pulse
0x00000424	4		KA W	Key MCA Multiscan Arm with Scan operation Arm (start scan with next LNE)
0x00000428	4	-	KA W	Key MCA Multiscan Arm with Scan operation Enable
0x0000042C	4	-	KA W	Key MCA Multiscan disable

Event information all ADC groups				
0x01000000	4	-	W only	Event configuration (all ADCs)
0x01000004	4		W only	End Address Threshold (all ADCs)
0x01000008	4	-	W only	Pretrigger Delay and Trigger Gate Length (all ADCs)
0x0100000C	4	-	W only	Raw Data Buffer Configuration (all ADCs)
0x01000040	4		W only	Energy Setup GP (all ADCs)
0x01000044	4		W only	Energy Gate Length (all ADCs)
0x01000048	4		W only	Energy Sample Length (all ADCs)
0x0100004C	4		W only	Energy Sample Start Index1 (all ADCs)
0x01000050	4		W only	Energy Sample Start Index2 (all ADCs)
0x01000054	4		W only	Energy Sample Start Index3 (all ADCs)
0x01000058	4		W only	Energy Tau Factor ADC1/3/5/7
0x0100005C	4		W only	Energy Tau Factor ADC2/4/6/8
0x01000060	4		W only	MCA Energy to Histogram Calculation Parameter ADC1357
0x01000064	4		W only	MCA Energy to Histogram Calculation Parameter ADC2468
0x01000068	4		W only	MCA Histogram Parameters (all ADCs)
0x01000070	4	-	W only	Event Extended configuration (all ADCs)

Event information ADC group 1				
0x02000000	4	-	R/W	Event configuration (ADC1, ADC2)
0x02000004	4		R/W	End Address Threshold (ADC1, ADC2)
0x02000008	4	-	R/W	Pretrigger Delay and Trigger Gate Length (ADC1, ADC2)
0x0200000C	4	-	R/W	Raw Data Buffer Configuration (ADC1, ADC2)
0x02000010	4	-	R	Actual Sample address ADC1
0x02000014	4	-	R	Actual Next Sample address ADC2
0x02000018	4		R	Previous Bank Sample address ADC1
0x0200001C	4		R	Previous Bank Sample address ADC2
0x02000020	4	-	R	Actual Sample Value (ADC1, ADC2)
0x02000024	4	-	R	internal Test
0x02000028	4	-	R	DDR2 Memory Logic Verification (ADC1, ADC2)
0x02000030	4		R/W	Trigger Setup ADC1
0x02000034	4		R/W	Trigger Threshold ADC1
0x02000038	4		R/W	Trigger Setup ADC2
0x0200003C	4		R/W	Trigger Threshold ADC2
0x02000040	4		R/W	Energy Setup GP (ADC1, ADC2)
0x02000044	4		R/W	Energy Gate Length (ADC1, ADC2)
0x02000048	4		R/W	Energy Sample Length (ADC1, ADC2)
0x0200004C	4		R/W	Energy Sample Start Index1 (ADC1, ADC2)
0x02000050	4		R/W	Energy Sample Start Index2 (ADC1, ADC2)
0x02000054	4		R/W	Energy Sample Start Index3 (ADC1, ADC2)
0x02000058	4		R/W	Energy Tau Factor ADC1
0x0200005C	4		R/W	Energy Tau Factor ADC2
0x02000060	4		R/W	MCA Energy to Histogram Calculation Parameter ADC1
0x02000064	4		R/W	MCA Energy to Histogram Calculation Parameter ADC2
0x02000068	4		R/W	MCA Histogram Parameters (ADC1, ADC2)

0x02000070	4		R/W	Event Extended configuration (ADC1, ADC2)
0x02000078	4		R/W	Trigger Extended Setup ADC1
0x0200007C	4		R/W	Trigger Extended Setup ADC2
0x02000080	4		R	MCA Trigger Start Counter ADC1
0x02000084	4		R	MCA Pileup Counter ADC1
0x02000088	4		R	MCA "Energy to high" counter ADC1
0x0200008C	4		R	MCA "Energy to low" counter ADC1
0x02000090	4		R	MCA Trigger Start Counter ADC2
0x02000094	4		R	MCA Pileup Counter ADC2
0x02000098	4		R	MCA "Energy to high" counter ADC2
0x0200009C	4		R	MCA "Energy to low" counter ADC2
0x020000A0	4		R/W	Trigger Extended Threshold ADC1
0x020000A4	4		R/W	Trigger Extended Threshold ADC2

Event information ADC group 2				
0x02800000	4	-	R/W	Event configuration (ADC3, ADC4)
And so on (as for ADC group 1)				

Event information ADC group 3				
0x03000000	4	-	R/W	Event configuration (ADC5, ADC6)
And so on (as for ADC group 1)				

Event information ADC group 4				
0x03800000	4	-	R/W	Event configuration (ADC7, ADC8)
And so on (as for ADC group 1)				

ADC memory pages				
0x04000000	8 MByte	X	R	ADC 1 memory page
0x04800000	8 MByte	X	R	ADC 2 memory page
0x05000000	8 MByte	X	R	ADC 3 memory page
0x05800000	8 MByte	X	R	ADC 4 memory page
0x06000000	8 MByte	X	R	ADC 5 memory page
0x06800000	8 MByte	X	R	ADC 6 memory page
0x07000000	8 MByte	X	R	ADC 7 memory page
0x07800000	8 MByte	X	R	ADC 8 memory page

4 Register/Resource Description

The 0x12xx firmware related registers are described in this section. The define statements were taken from the sis3302_v1201.h header file. Examples refer to the C code which is underlying the sis3150_3302_gamma CVI project.

4.1 Control/Status register

```
#define SIS3302_CONTROL_STATUS      0x0      /* read/write; D32 */
```

The control register is implemented as a selective J/K register, a specific function is enabled by writing a 1 into the set/enable bit, the function is disabled by writing a 1 into the clear/disable bit (which location is 16-bit higher in the register). An undefined toggle status will result from setting both the enable and disable bits for a specific function at the same time. The only function at this point in time is user LED on/off.

On read access the same register represents the status register.

Bit	write Function	read Function
31	Clear reserved 15 (*)	0
30	Clear reserved 14 (*)	0
29	Clear reserved 13 (*)	0
28	Clear reserved 12 (*)	0
27	Clear reserved 11 (*)	0
26	Clear reserved 10 (*)	0
25	Clear reserved 9 (*)	0
24	Clear reserved 8 (*)	0
23	Clear reserved 7 (*)	0
22	Clear reserved 6 (*)	0
21	Clear reserved 5 (*)	0
20	Clear reserved 4 (*)	0
19	Clear reserved 3 (*)	0
18	Clear reserved 2 (*)	0
17	Clear reserved 1 (*)	0
16	Switch off user LED (*)	0
15	Set reserved 15	Status reserved 15
14	Set reserved 14	Status reserved 14
13	Set reserved 13	Status reserved 13
12	Set reserved 12	Status reserved 12
11	Set reserved 11	Status reserved 11
10	Set reserved 10	Status reserved 10
9	Set reserved 9	Status reserved 9
8	Set reserved 8	Status reserved 8
7	Set reserved 7	Status reserved 7
6	Set reserved 7	Status reserved 6
5	Set reserved 7	Status reserved 4
4	Set reserved 7	Status reserved 4
3	Set reserved 3	Status reserved 3
2	Set reserved 2	Status reserved 2
1	Set reserved 1	Status reserved 1
0	Switch on user LED	Status User LED (1=LED on, 0=LED off)

(*) denotes power up default setting

4.2 Module Id. and Firmware Revision register

```
#define SIS3302_MODID          0x4          /* read only; D32 */
```

This register reflects the module identification of the SIS3302 and its minor and major firmware revision levels. The major revision level will be used to distinguish between substantial design differences and experiment specific designs, while the minor revision level will be used to mark user specific adaptations.

Bit	Function	Reading
31	Module Id. Bit 15	3
30	Module Id. Bit 14	
29	Module Id. Bit 13	
28	Module Id. Bit 12	
27	Module Id. Bit 11	3
26	Module Id. Bit 10	
25	Module Id. Bit 9	
24	Module Id. Bit 8	
23	Module Id. Bit 7	0
22	Module Id. Bit 6	
21	Module Id. Bit 5	
20	Module Id. Bit 4	
19	Module Id. Bit 3	2
18	Module Id. Bit 2	
17	Module Id. Bit 1	
16	Module Id. Bit 0	
15	Major Revision Bit 7	
14	Major Revision Bit 6	
13	Major Revision Bit 5	
12	Major Revision Bit 4	
11	Major Revision Bit 3	
10	Major Revision Bit 2	
9	Major Revision Bit 1	
8	Major Revision Bit 0	
7	Minor Revision Bit 7	
6	Minor Revision Bit 6	
5	Minor Revision Bit 5	
4	Minor Revision Bit 4	
3	Minor Revision Bit 3	
2	Minor Revision Bit 2	
1	Minor Revision Bit 1	
0	Minor Revision Bit 0	

4.2.1 Major revision numbers

Find below a table with major revision numbers used to date

Major revision number	Application/user
0x01	Generic designs
0x12	Gamma
0x14	Gamma (add MCA Mode)

4.3 Interrupt configuration register

```
#define SIS3302_IRQ_CONFIG      0x8      /* read/write; D32 */
```

This read/write register controls the VME interrupt behaviour of the SIS3302 ADC. Four interrupt sources are foreseen, for the time being two of them are associated with an interrupt condition, two condition are reserved for future use.

The interrupter type is DO8 .

4.3.1 IRQ mode

In RORA (release on register access) mode the interrupt will be pending until the IRQ source is cleared by specific access to the corresponding disable VME IRQ source bit. After the interrupt is serviced the source has to be activated with the enable VME IRQ source bit again.

In ROAK (release on acknowledge) mode , the interrupt condition will be cleared (and the IRQ source disabled) as soon as the interrupt is acknowledged by the CPU. After the interrupt is serviced the source has to be activated with the enable VME IRQ source bit again.

Bit	Function	Default
31		0
...		0
16		0
15		0
14		0
13		0
12	RORA/ROAK Mode (0: RORA; 1: ROAK)	0
11	VME IRQ Enable (0=IRQ disabled, 1=IRQ enabled)	0
10	VME IRQ Level Bit 2	0
9	VME IRQ Level Bit 1	0
8	VME IRQ Level Bit 0 (0 always)	0
7	IRQ Vector Bit 7; placed on D7 during VME IRQ ACK cycle	0
6	IRQ Vector Bit 6; placed on D6 during VME IRQ ACK cycle	0
5	IRQ Vector Bit 5; placed on D5 during VME IRQ ACK cycle	0
4	IRQ Vector Bit 4; placed on D4 during VME IRQ ACK cycle	0
3	IRQ Vector Bit 3; placed on D3 during VME IRQ ACK cycle	0
2	IRQ Vector Bit 2; placed on D2 during VME IRQ ACK cycle	0
1	IRQ Vector Bit 1; placed on D1 during VME IRQ ACK cycle	0
0	IRQ Vector Bit 0; placed on D0 during VME IRQ ACK cycle	0

The power up default value reads 0x 00000000

4.4 Interrupt control register

```
#define SIS3302_IRQ_CONTROL          0xC          /* read/write; D32 */
```

This register controls the VME interrupt behaviour of the SIS3302 ADC. Four interrupt sources are foreseen, for the time being two of them are associated with an interrupt condition, two condition are reserved for future use.

Bit	Function (w)	(r)	Default
31	Update IRQ Pulse	Status IRQ source 7 (reserved)	0
30	Unused	Status IRQ source 6 (reserved)	0
29	Unused	Status IRQ source 5 (reserved)	0
28	Unused	Status IRQ source 4 (reserved)	0
27	Unused	Status IRQ source 3 (reserved)	0
26	Unused	Status IRQ source 2 (reserved)	0
25	Unused	Status IRQ source 1 (End Address Threshold Flag; level sensitive)	0
24	Unused	Status IRQ source 0 (End Address Threshold Flag; edge sensitive)	0
23	Disable/Clear IRQ source 7	Status flag source 7	0
22	Disable/Clear IRQ source 6	Status flag source 6	0
21	Disable/Clear IRQ source 5	Status flag source 5	0
20	Disable/Clear IRQ source 4	Status flag source 4	0
19	Disable/Clear IRQ source 3	Status flag source 3	0
18	Disable/Clear IRQ source 2	Status flag source 2	0
17	Disable/Clear IRQ source 1	Status flag source 1	0
16	Disable/Clear IRQ source 0	Status flag source 0	0
15	Unused	Status VME IRQ	0
14	Unused	Status internal IRQ	0
13	Unused	0	0
12	Unused	0	0
11	Unused	0	0
10	Unused	0	0
9	Unused	0	0
8	Unused	0	0
7	Enable IRQ source 7	Status enable source 7 (read as 1 if enabled, 0 if disabled)	0
6	Enable IRQ source 6	Status enable source 6 (read as 1 if enabled, 0 if disabled)	0
5	Enable IRQ source 5	Status enable source 5 (read as 1 if enabled, 0 if disabled)	0
4	Enable IRQ source 4	Status enable source 4 (read as 1 if enabled, 0 if disabled)	0
3	Enable IRQ source 3	Status enable source 3 (read as 1 if enabled, 0 if disabled)	0
2	Enable IRQ source 2	Status enable source 2 (read as 1 if enabled, 0 if disabled)	0
1	Enable IRQ source 1	Status enable source 1 (read as 1 if enabled, 0 if disabled)	0
0	Enable IRQ source 0	Status enable source 0 (read as 1 if enabled, 0 if disabled)	0

The power up default value reads 0x 00000000

IRQ source 3: reserved
 IRQ source 2: reserved
 IRQ source 1: reached Address Threshold (level sensitive)
 IRQ source 0: reached Address Threshold (edge sensitive)

4.5 Acquisition control register

```
#define SIS3302_ACQUISTION_CONTROL    0x10    /* read/write; D32 */
#define SIS3302_ACQUISITION_CONTROL  0x10    /* read/write; D32 */
```

Note: missing I in ACQUISITION in older header files

The acquisition control register is in charge of most of the settings related to the actual configuration of the digitization process.

Like the control register it is implemented in a J/K fashion.

Bit	Write Function	Read
31	Clear reserved 15 (*)	0
30	Clear Clock Source bit2 (*)	0
29	Clear Clock Source bit1 (*)	0
28	Clear Clock Source bit0 (*)	0
27	Clear reserved 11 (*)	0
26	Disable front panel LEMO In 1 (*)	0
25	Disable front panel LEMO In 2 (*)	0
24	Disable front panel LEMO In 3 (*)	0
23	Clear reserved 7 (*)	0
22	Disable ored Internal Trigger to External Trigger In (*)	0
21	Clear LEMO OUT Mode bit 1 (*)	Status of MCA Multiscan Busy
20	Clear LEMO OUT Mode bit 0 (*)	Status of MCA Scan Busy
19	Clear MCA Mode bit (*)	Status of End Address Threshold Flag
18	Clear LEMO IN Mode bit 2 (*)	Status of ADC-Sample-Logic Busy (Armed)
17	Clear LEMO IN Mode bit 1 (*)	Status of ADC-Sample-Logic Armed Bank2
16	Clear LEMO IN Mode bit 0 (*)	Status of ADC-Sample-Logic Armed Bank1
15	Set reserved 15	Status reserved 15
14	Set clock source bit 2	Status clock source bit 2
13	Set clock source bit 1	Status clock source bit 1
12	Set clock source bit 0	Status clock source bit 0
11	Set reserved 11	Status reserved 11
10	Enable front panel LEMO In 1	Status front panel LEMO In 1 Enable bit
9	Enable front panel LEMO In 2	Status front panel LEMO In 2 Enable bit
8	Enable front panel LEMO In 3	Status front panel LEMO In 3 Enable bit
7	Set reserved 7	Status reserved 7
6	Enable ored Internal Trigger to External Trigger In (Feedback)	Status ored Internal Trigger to External Trigger In (Feedback)
5	Set LEMO OUT Mode bit 1	Status LEMO OUT Mode bit 1
4	Set LEMO OUT Mode bit 0	Status LEMO OUT Mode bit 0
3	Set MCA Mode bit	Status MCA Mode bit
2	Set LEMO IN Mode bit 2	Status LEMO IN Mode bit 2
1	Set LEMO IN Mode bit 1	Status LEMO IN Mode bit 1
0	Set LEMO IN Mode bit 0	Status LEMO IN Mode bit 0

(*) The power up default value reads 0x0

Clock source bit setting table:

Clock Source Bit2	Clock Source Bit1	Clock Source Bit0	Clock Source
0	0	0	internal 100 MHz
0	0	1	internal 50 MHz
0	1	0	internal 25 MHz
0	1	1	internal 10 MHz
1	0	0	internal 1 MHz
1	0	1	internal 100 MHz
1	1	0	external clock (LEMO front panel) ; min. 1 MHz
1	1	1	Second internal 100 MHz

Note:

The internal 100 MHz is generated with a DLL in the FPGA from the internal 50 MHz.
To get a better resolution use the “Second internal 100 MHz” instead of “internal 100 MHz”.
(U212 must be assembled with a 100 MHz 3.3 V oscillator)

LEMO OUT Mode bit setting table:

Lemo Output Mode **Lemo Output assignment**
with MCA Mode = 0

Mode 0
(bit1=0, bit0=0)

output 3 -> ADC sample logic armed
output 2 -> ADCx event sampling busy
output 1 -> Trigger output

Mode 1
(bit1=0, bit0=1)

output 3 -> ADC sample logic armed
output 2 -> ADCx event sampling busy or ADC sample logic not armed (Veto)
output 1 -> Trigger output

Mode 2
(bit1=1, bit0=0)

output 3 -> ADC N+1 Neighbor Trigger/Gate Out
output 2 -> Trigger output
output 1 -> ADC N-1 Neighbor Trigger/Gate Out

Mode 3
(bit1=1, bit0=1)

output 3 -> ADC N+1 Neighbor Trigger/Gate Out
output 2 -> ADC sampling busy or ADC sample logic not armed (Veto)
output 1 -> ADC N-1 Neighbor Trigger/Gate Out

Lemo Output Mode
with MCA Mode = 1**Lemo Output assignment**

Mode 0 (bit1=0, bit0=0)	output 3 -> ADC sample logic armed output 2 -> ADCx event sampling busy output 1 -> Trigger output
Mode 1 (bit1=0, bit0=1)	output 3 -> Multiscan first scan signal output 2 -> LNE output 1 -> Scan enable
Mode 2 (bit1=1, bit0=0)	output 3 -> Scan enable output 2 -> LNE output 1 -> Trigger output
Mode 3 (bit1=1, bit0=1)	output 3 -> reserved output 2 -> reserved output 1 -> reserved

MCA Mode bit= 0: MCA Mode is disabled

MCA Mode bit= 1: MCA Mode is enabled

The Energy Histograms are build in the ADCx memories.

LEMO IN Mode bit setting table:

Lemo Input Mode
with MCA Mode = 0

Lemo Input assignment

Mode 0
(bit2=0, bit1=0, bit0=0)

input 3 -> Trigger
input 2 -> Timestamp Clear
input 1 -> Veto

Mode 1
(bit2=0, bit1=0, bit0=1)

input 3 -> Trigger
input 2 -> Timestamp Clear
input 1 -> Gate

Mode 2
(bit2=0, bit1=1, bit0=0)

input 3 -> reserved
input 2 -> reserved
input 1 -> reserved

Mode 3
(bit2=0, bit1=1, bit0=1)

input 3 -> reserved
input 2 -> reserved
input 1 -> reserved

Mode 4
(bit2=0, bit1=1, bit0=0)

input 3 -> ADC N+1 Neighbor Trigger/Gate In
input 2 -> Trigger
input 1 -> ADC N-1 Neighbor Trigger/Gate In

Mode 5
(bit2=1, bit1=0, bit0=1)

input 3 -> ADC N+1 Neighbor Trigger/Gate In
input 2 -> Timestamp Clear
input 1 -> ADC N-1 Neighbor Trigger/Gate In

Mode 6
(bit2=1, bit1=1, bit0=0)

input 3 -> ADC N+1 Neighbor Trigger/Gate In
input 2 -> Veto
input 1 -> ADC N-1 Neighbor Trigger/Gate In

Mode 7
(bit2=1, bit1=1, bit0=1)

input 3 -> ADC N+1 Neighbor Trigger/Gate In
input 2 -> Gate
input 1 -> ADC N-1 Neighbor Trigger/Gate In

Lemo Input Mode
with MCA Mode = 1

Lemo Input assignment

Mode 0
(bit2=0, bit1=0, bit0=0)

input 3 -> reserved
input 2 -> external MCA_Start (histogram ptr reset/start pulse)
input 1 -> external next pulse (LNE)

Mode 1
(bit2=0, bit1=0, bit0=1)

input 3 -> Trigger
input 2 -> external MCA_Start (histogram ptr reset/start pulse)
input 1 -> external next pulse (LNE)

Mode 2
(bit2=0, bit1=1, bit0=0)

input 3 -> Veto
input 2 -> external MCA_Start (histogram ptr reset/start pulse)
input 1 -> external next pulse (LNE)

Mode 3
(bit2=0, bit1=1, bit0=1)

input 3 -> Gate
input 2 -> external MCA_Start (histogram ptr reset/start pulse)
input 1 -> external next pulse (LNE)

Mode 4 to 7

reserved

4.6 Broadcast setup register

```
#define SIS3302_CBLT_BROADCAST_SETUP      0x30      /* read/write; D32 */
```

This read/write register defines, whether the SIS3302 will participate in a Broadcast. The configuration of this register and the registers of other participating modules is essential for proper Broadcast behaviour.

Bit	Function
31	Broadcast address bit 31
30	Broadcast address bit 30
29	Broadcast address bit 29
28	Broadcast address bit 28
27	Broadcast address bit 27
26	reserved
25	reserved
24	reserved
23	reserved
22	reserved
21	reserved
20	reserved
19	reserved
18	reserved
17	reserved
16	reserved
15	reserved
14	reserved
13	reserved
12	reserved
11	reserved
10	0
9	0
8	0
7	0
6	0
5	Enable Broadcast Master
4	Enable Broadcast
3	0
2	reserved
1	reserved
0	reserved

Broadcast functionality is implemented for all Key address cycles. Modules which are supposed to participate in a broadcast have to get the same broadcast address. The broadcast address is defined by the upper 5 bits of the broadcast setup register. One module has to be configured as broadcast master, the enable broadcast bit has to be set for all modules as illustrated below.

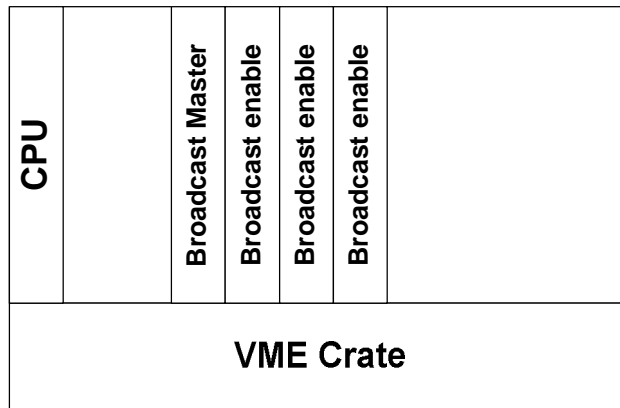

Broadcast setup example (broadcast address 0x38000000):

Module	Broadcast Setup Register	Comment
1	0x38000030	Broadcast Master
2	0x38000010	Broadcast enable
3	0x38000010	Broadcast enable
4	0x38000010	Broadcast enable

All 4 modules will participate in a key reset (A32/D32 write) to address 0x38000400.

Note: Do not use a broadcast address that is an existing VME address of a VME card in the crate.

4.7 ADC Memory Page register

```
#define SIS3302_ADC_MEMORY_PAGE_REGISTER 0x34      /* read/write; D32 */
```

The SIS3302 default memory size per channel is 64 MByte (i.e. 32 MSample).

The VME address space window per ADC is limited to 8 MByte (4 MSample) however. The read/write ADC memory page register is used to select one of the 8 memory subdivisions (pages).

Bit	Function
31	reserved
..	
..	
4	reserved
3	Page register bit 3 (reserved)
2	Page register bit 2
1	Page register bit 1
0	Page register bit 0

Example: dual 1/2 memory buffer acquisition scheme
(see sis3150_gamma_running.c)

```
data = 0x0 ; //Bank2 is armed and Bank1 (page 0) has to be readout
if (bank1_armed_flag == 1) { // Bank1 is armed and Bank2 (page 4) has to be readout
    data = 0x4 ;
}
addr = gl_uint_ModAddrRun[module_index] + SIS3302_ADC_MEMORY_PAGE_REGISTER ;
if ((error = sub_vme_A32D32_write(addr,data )) != 0) {
    sisVME_ErrorHandling(error, gl_uint_ModAddrRun[module_index],
        "sub_vme_A32D32_write");
    return -1;
}
```

4.8 DAC Control Registers

```
#define SIS3302_DAC_CONTROL_STATUS      0x50      /* read/write; D32 */
```

This set of registers is used to program the 16-bit offset DACs for the 8 ADC channels. Refer to the documentation of the AD5570 DAC chip for details also and have a look to the configuration example in `sis3302_adc_test1.c` (CVI directory)

Example routine:

```
int sis3302_write_dac_offset( unsigned int module_addr,
                             unsigned int *offset_value_array)
```

4.8.1 DAC Control/Status register (read/write)

```
#define SIS3302_DAC_CONTROL_STATUS 0x50      /* read/write; D32 */
```

Bit	Write Function	Read Function
31	None	0
..
..
16	None	0
15	None	DAC Read/Write/Clear Cycle BUSY
14	None	0
...		...
8	None	0
7	None	0
6	DAC selection Bit 2	status of DAC selection Bit 2
5	DAC selection Bit 1	status of DAC selection Bit 1
4	DAC selection Bit 0	status of DAC selection Bit 0
3
2	none	0
1	DAC Command Bit 1	DAC Command Bit 1 Status
0	DAC Command Bit 0	DAC Command Bit 0 Status

DAC Command Bit

Bit 1	Bit 0	Function
0	0	No function
0	1	Load shift register of selected DAC
1	0	Load selected DAC
1	1	Clear all DACs

A “Clear DAC” command sets the value of all DACs to analog ground

4.8.2 DAC Data register

```
#define SIS3302_DAC_DATA          0x54          /* read/write; D32 */
```

Bit	Write Function	Read Function
31	none	DAC Input Register Bit 15 (from DAC)
..
..
16	none	DAC Input Register Bit 0
15	DAC Output Register Bit 15	DAC Output Register Bit 15
..	..	0
..	..	0
0	DAC Output Register Bit 0	DAC Output Register Bit 0

4.8.3 DAC load sequence

The sequence to load the DAC of a single channel is shown below.

The example routine `sis3302_write_dac_offset` loads the 8 DACs of a SIS3302 module at base address `module_` offset in a loop.

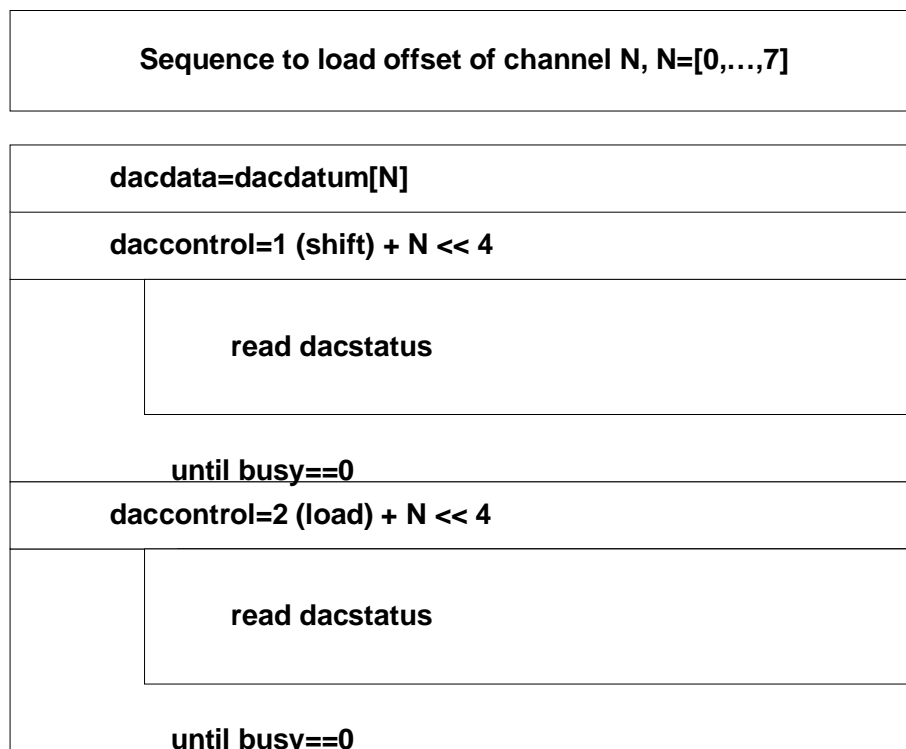

Find below a DAC scan that was acquired with the DAC test function of the SIS3302 ADC Labwindows application. The SIS3302 under test was configured for an input span of some $2 V_{pkpk}$. It can be seen, that a DAC offset of some 37000 counts is required to accomplish an input range of $-1...+1V$ on this particular channel.

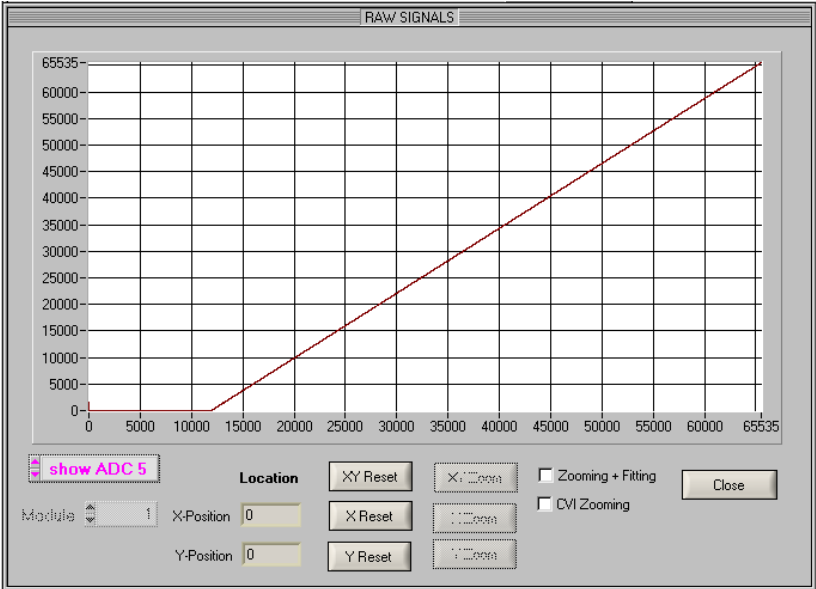

Note: The actual sample value registers can be used to monitor the influence of the DAC settings on the ADC values.

4.9 MCA Scan Nof Histograms preset register

```
#define SIS3302_MCA_SCAN_NOF_HISTOGRAMS_PRESET 0x80
```

The number of histograms in a MCA Scan operation can be preset/limited with this 32-bit deep register.

The entry of 0x0 (power up default) results in disabling the preset/limited function .

Histogram filling wraps at the 64 MByte Page Boundary while the Histogram counter continues incrementing.

4.10 MCA Scan Histogram counter register

```
#define SIS3302_MCA_SCAN_HISTOGRAM_COUNTER 0x84
```

This 32-bit deep register holds the actual number of histograms in MCA Scan operation. Histogram numbering starts with 0.

4.11 MCA Scan LNE Setup and Prescaler Factor register

```
#define SIS3302_MCA_SCAN_SETUP_PRESCALE_FACTOR 0x88
```

D31:29	D28	D27:0
Reserved	LNE source bit	LNE prescale factor

LNE source bit	LNE source
0	external next pulse (LNE); see Lemo Input Mode
1	internal 10 MHz

The LNE prescale factor register allows you to prescale the LNE pulse (external next pulse or internal 10MHz). The prescale factor is a 28-bit value. in MCA Scan operation.

LNE prescale factor	LNE pulse
0	(internal 10 MHz or external LNE)
1	(internal 10 MHz or external LNE) / 2
2	(internal 10 MHz or external LNE) / 3
3	(internal 10 MHz or external LNE) / 4
..	..

4.12 MCA Scan Control register

#define SIS3302_MCA_SCAN_CONTROL

0x8C

Bit	Function
31	None
..	..
16	None
15	None
..	..
8	None
7	None
6	None
5	None
4	Start Scan on Bank 2 bit
3	None
2	None
1	None
0	Scan Histogram Autoclear disable bit

Scan Histogram Autoclear disable bit = 0:

Scan Mode: Autoclear is enabled

Multiscan Mode: Autoclear is enabled for 1. Scan and disabled for the following Scans.

Scan Histogram Autoclear disable bit = 1:

Scan Mode: Autoclear is disabled

Multiscan Mode: Autoclear is disabled

Start Scan on Bank 2 bit = 0: start address of 1. histogram is 0x0 (first page)

Start Scan on Bank 2 bit = 1: start address of 1. histogram is 0x0040 0000 (4 Mbyte offset)

Write to this register only if MCA Multiscan or Scan is not Busy.

4.13 MCA Multiscan Nof Scans preset register

```
#define SIS3302_MCA_MULTISCAN_NOF_SCANS_PRESET 0x90
```

The number of scans in a MCA Multiscan operation can be preset/limited with this 32-bit deep register.

The entry of 0x0 (power up default) results in disabling the preset/limited function.

4.14 MCA Multiscan Scan counter register

```
#define SIS3302_MCA_MULTISCAN_SCAN_COUNTER 0x94
```

This 32-bit deep register holds the actual number of scans in MCA Multiscan operation. The register content is updated with the start signal/pulse.

4.15 MCA Multiscan Last Scan Histogram counter register

```
#define SIS3302_MCA_MULTISCAN_LAST_SCAN_HISTOGRAM_COUNTER 0x98
```

This 32-bit deep register holds the number of histograms of the last (earlier) scan in MCA Multiscan operation. It is updated with the start in MCA Multiscan operation.

4.16 Key address general reset (0x400)

```
#define SIS3302_KEY_RESET 0x400 /* write only; D32 */
```

A write with arbitrary data to this register (key address) resets the SIS3302 to its power up state.

4.17 Key address Sample Logic reset (0x404)

```
#define SIS3302_KEY_0x404_SAMPLE_LOGIC_RESET 0x404 /* write only; D32 */
```

A write with arbitrary data to this register (key address) resets the sampling logic. The moving average sums are cleared at the same time.

This key write has to be used after the P and G parameters are updated and before a key arm is issued. Undefined behavior (negative sign e.g.) may result otherwise.

4.18 Key addresses with MCA mode = 0

4.18.1 Key address Sample Logic reset (0x410)

```
#define SIS3302_KEY_SAMPLE_LOGIC_RESET 0x410 /* write only; D32 */
```

A write with arbitrary data to this register (key address) resets the sampling logic. The moving average sums are cleared at the same time.

This key write has to be used after the P and G parameters are updated and before a key arm is issued. Undefined behavior (negative sign e.g.) may result otherwise.

4.18.2 Key address VME Disarm Sample logic (0x414)

```
#define SIS3302_KEY_DISARM 0x414 /* write only; D32 */
```

A write with arbitrary data to this register (key address) will disarm the sampling logic.

4.18.3 Key address VME Trigger (0x418)

```
#define SIS3302_KEY_Trigger 0x418 /* write only; D32 */
```

A write with arbitrary data to this register (key address) will trigger the sampling logic if “external trigger” is enabled (see Event configuration registers).

4.18.4 Key address Timestamp Clear (0x41C)

```
#define SIS3302_KEY_TIMESTAMP_CLEAR 0x41C /* write only; D32 */
```

A write with arbitrary data to this register (key address) clears the 48-bit Timestamp counter.

4.18.5 Key address Disarm Sample Logic and Arm sampling on Bank 1 (0x420)

```
#define SIS3302_KEY_DISARM_AND_ARM_BANK1      0x420  /* write only; D32 */
```

Disarms sampling on current bank and arms bank 1.

4.18.6 Key address Disarm Sample Logic and Arm sampling on Bank 2 (0x424)

```
#define SIS3302_KEY_DISARM_AND_ARM_BANK2      0x424  /* write only; D32 */
```

Disarms sampling on current bank and arms bank 2. Used in dual bank acquisition as illustrated in the example below.

Example (from sis3150_gamma_running.c):

```
if (bank1_armed_flag == 1) {
    addr = gl_uint_ModAddrRun[0] + SIS3302_KEY_DISARM_AND_ARM_BANK2 ;
    bank1_armed_flag = 0; // bank 2 is armed
}
else {
    addr = gl_uint_ModAddrRun[0] + SIS3302_KEY_DISARM_AND_ARM_BANK1 ;
    bank1_armed_flag = 1; // bank 2 is armed
}
if ((error = sub_vme_A32D32_write(addr,0x0 )) != 0) {
    sisVME_ErrorHandling (error, addr, "sub_vme_A32D32_write") ;
}
```

4.19 Key addresses with MCA mode = 1

4.19.1 Key address MCA Scan LNE pulse (0x410)

```
#define SIS3302_KEY_MCA_SCAN_LNE_PULSE      0x410  /* write only; D32 */
```

A write with arbitrary data to this address issues a LNE (load next event, advance to next histogram) in MCA mode.

4.19.2 Key address MCA Scan Operation Arm (0x414)

```
#define SIS3302_KEY_MCA_SCAN_ARM            0x414  /* write only; D32 */
```

A write with arbitrary data to this address arms the module in MCA mode. The MCA Scan operation will start with next LNE signal or Key MCA Scan LNE pulse the MCA Scan operation..

4.19.3 Key address MCA Scan Enable (0x418)

```
#define SIS3302_KEY_MCA_SCAN_START          0x418    /* write only; D32 */
```

A write with arbitrary data to this address enables (starts) the MCA Scan operation.

4.19.4 Key address MCA Scan Disable (0x41C)

```
#define SIS3302_KEY_MCA_SCAN_DISABLE       0x41C    /* write only; D32 */
```

A write with arbitrary data to this address disables the MCA Scan operation.

4.19.5 Key address MCA Multiscan Start/Reset pulse (0x420)

```
#define SIS3302_KEY_MCA_MULTISCAN_START_RESET_PULSE 0x420    /* wr; D32 */
```

A write with arbitrary data to this address issues a start pulse in MCA Multiscan mode.

4.19.6 Key address MCA Multiscan Arm with Scan operation Arm (0x424)

```
#define SIS3302_KEY_MCA_MULTISCAN_ARM_SCAN_ARM      0x424    /* wr; D32 */
```

A write with arbitrary data to this address arms the MCA Multiscan operation (it starts with Start/Reset pulse) . After the MCA Multiscan operation is started the logic arms the MCA Scan operation (the Scan operation starts with next LNE).

4.19.7 Key address MCA Multiscan Arm with Scan operation Enable (0x428)

```
#define SIS3302_KEY_MCA_MULTISCAN_ARM_SCAN_ENABLE   0x428    /* wr; D32 */
```

A write with arbitrary data to this address arms the MCA Multiscan operation (it starts with Start/Reset pulse) . After the MCA Multiscan operation is started the logic enables (starts) the MCA Scan operation.

4.19.8 Key address MCA Multiscan Disable (0x42C)

```
#define SIS3302_KEY_MCA_MULTISCAN_DISABLE          0x42C    /* wr; D32 */
```

A write with arbitrary data to this address disables MCA Multiscan operation.

4.20 Event configuration registers

```
#define SIS3302_EVENT_CONFIG_ALL_ADC      0x01000000 /* write only;D32 */
#define SIS3302_EVENT_CONFIG_ADC12      0x02000000 /* read/write;D32 */
#define SIS3302_EVENT_CONFIG_ADC34      0x02800000 /* read/write;D32 */
#define SIS3302_EVENT_CONFIG_ADC56      0x03000000 /* read/write;D32 */
#define SIS3302_EVENT_CONFIG_ADC78      0x03800000 /* read/write;D32 */
```

This register is implemented for each channel group. The `SIS3302_EVENT_CONFIG_ALL_ADC` register can be used to write the same setting to the registers of all channel groups simultaneously.

Bit	Function
31	HEADER_ADC_ID bit 15
30	..
..	..
21	..
20	HEADER_ADC_ID bit 4
19	HEADER_ADC_ID bit 3
18	Channel Group ID Bit 1 (read only), used as HEADER_ADC_ID bit 2
17	Channel Group ID Bit 0 (read only), used as HEADER_ADC_ID bit 1
16	Unused
15	ADC 2 ADC N+1 Next Neighbor gate enable
14	ADC 2 ADC N-1 Next Neighbor gate enable
13	ADC 2 external gate enable
12	ADC 2 internal gate enable
11	ADC 2 external trigger enable
10	ADC 2 internal trigger enable
9	reserved
8	ADC 2 input invert bit
7	ADC 1 ADC N+1 Next Neighbor gate enable
6	ADC 1 ADC N-1 Next Neighbor gate enable
5	ADC 1 external gate enable
4	ADC 1 internal gate enable
3	ADC 1 external trigger enable (synchronous mode)
2	ADC 1 internal trigger enable (asynchronous mode)
1	Reserved
0	ADC 1 input invert bit

ADCx input invert bit = 0: use for positive signals
 ADCx input invert bit = 1: use for negative signals

4.21 Event Extended configuration registers

```
#define SIS3302_EVENT_EXTENDED_CONFIG_ALL_ADC 0x01000070 /* write; D32 */
#define SIS3302_EVENT_EXTENDED_CONFIG_ADC12 0x02000070 /* read/write */
#define SIS3302_EVENT_EXTENDED_CONFIG_ADC34 0x02800070 /* read/write */
#define SIS3302_EVENT_EXTENDED_CONFIG_ADC56 0x03000070 /* read/write */
#define SIS3302_EVENT_EXTENDED_CONFIG_ADC78 0x03800070 /* read/write */
```

This register is implemented for each channel group. The `SIS3302_EVENT_EXTENDED_CONFIG_ALL_ADC` register can be used to write the same setting to the registers of all channel groups simultaneously.

Bit	Function
31	Reserved
30	..
..	..
21	..
20	Reserved
19	Reserved
18	Reserved
17	Reserved
16	Reserved
15	ADC 2 ADC N+1 Next Neighbor trigger enable
14	ADC 2 ADC N-1 Next Neighbor trigger enable
13	Reserved
12	Reserved
11	Reserved
10	Reserved
9	reserved
8	ADC2 Trigger-50KHz Enable bit
7	ADC 1 ADC N+1 Next Neighbor trigger enable
6	ADC 1 ADC N-1 Next Neighbor trigger enable
5	Reserved
4	Reserved
3	Reserved
2	Reserved
1	Reserved
0	ADC1 Trigger-50KHz Enable bit

ADCx Trigger-50KHz Enable bit:

if set then triggers are generated with 50KHz (with ADC clock = 100MHz).

This feature is useful for ADC value histogramming in MCA mode.

4.22 End Address Threshold registers

```
#define SIS3302_END_ADDRESS_THRESHOLD_ALL_ADC      0x01000004

#define SIS3302_END_ADDRESS_THRESHOLD_ADC12      0x02000004
#define SIS3302_END_ADDRESS_THRESHOLD_ADC34      0x02800004
#define SIS3302_END_ADDRESS_THRESHOLD_ADC56      0x03000004
#define SIS3302_END_ADDRESS_THRESHOLD_ADC78      0x03800004
```

These registers define the “End Address Threshold” values for the ADC channel groups.

The value of the Actual Next Sample address counter will be compared with value of the End Address Threshold register.

The value is given in samples (i.e. number of 16-bit words)

Bit	
31	unused, read as 0
...	
24	unused, read as 0
23	End Address Threshold Bit 23
..	
2	End Address Threshold Bit 2
1	unused, read as 0
0	unused, read as 0

The power up default value is 0

4.23 Pretrigger Delay and Trigger Gate Length registers

```
#define SIS3302_PRETRIGGER_DELAY_TRIGGERGATE_LENGTH_ALL_ADC      0x01000008
#define SIS3302_PRETRIGGER_DELAY_TRIGGERGATE_LENGTH_ADC12      0x02000008
#define SIS3302_PRETRIGGER_DELAY_TRIGGERGATE_LENGTH_ADC34      0x02800008
#define SIS3302_PRETRIGGER_DELAY_TRIGGERGATE_LENGTH_ADC56      0x03000008
#define SIS3302_PRETRIGGER_DELAY_TRIGGERGATE_LENGTH_ADC78      0x03800008
```

This register defines the length of the Trigger Gate (1 to 65536) and the Pretrigger Delay (0 to 1023). The used value for the Pretrigger Delay is the set value – 2 (with a wrap behaviour as illustrated in the table below).

Written value	Trigger Gate Length
0	1
1	2
2	3
3	4
4	2
65535	65536

Written value	Pretrigger Delay
0	1022
1	1023
2	0
3	1
4	2
510	508
511	509
1022	1020
1023	1021

Register bit assignments:

D31:25	D24:16	D15:0
0	Pretrigger Delay (-2)	Trigger Gate Length (+1)

The power up default value is 0

Example:

Desired Trigger Gate Length of 1024 clocks and a Pretrigger Delay of 256 clocks (samples) -
> set the register to 0x 0102 03FF

Note: The Trigger Gate Length is independent from the Trigger Decimation Mode !

4.24 Raw Data Buffer Configuration registers

```
#define SIS3302_RAW_DATA_BUFFER_CONFIG_ALL_ADC      0x0100000C
#define SIS3302_RAW_DATA_BUFFER_CONFIG_ADC12      0x0200000C
#define SIS3302_RAW_DATA_BUFFER_CONFIG_ADC34      0x0280000C
#define SIS3302_RAW_DATA_BUFFER_CONFIG_ADC56      0x0300000C
#define SIS3302_RAW_DATA_BUFFER_CONFIG_ADC78      0x0380000C
```

This register is used to configure the number of samples of raw data to be acquired and to define the number of pre trigger samples (combination of “Raw Data Sample Start Index” and “Pretrigger Delay”).

While the Trigger Gate is active the logic compares the value of the Trigger Gate Index (an internal counter, which is cleared at the beginning of the event and incremented by each clock)

with the value of the “Raw Data Sample Start Index” register. If the result of the compare is equal then the logic writes N values (“Raw Data Sample Length”) into the Raw Data Buffer.

Both values are 16-bit deep. The number of samples has to be quad sample aligned and the number of pre trigger samples has to be even.

The number of “Raw Data Sample Length” is limited to 65532 samples!

Note: The register is implemented on the FPGA group level also.

Bit	Function
31	Bit 15 of Raw Data Sample Length
...	...
18	Bit 2 of Raw Data Sample Length
17	0 (quad sample aligned values only)
16	0 (quad sample aligned values only)
15	Bit 15 of Raw Data Sample Start Index
...	...
1	Bit 1 of Raw Data Sample Start Index
0	0 (even values only)

Example:

```
data =      (gl_uint_RawPreSampleStart_index & 0xfffe)
           + ((gl_uint_RawSampleLength & 0xffffc) << 16) ;
addr = module_addr + SIS3302_RAW_DATA_BUFFER_CONFIG_ALL_ADC ;
if ((error = sub_vme_A32D32_write(addr,data )) != 0) {
    sisVME_ErrorHandling (error, addr, "sub_vme_A32D32_write") ;
}
```

4.25 ADC1-8 Next Sample address register

```
#define SIS3302_ACTUAL_NEXT_SAMPLE_ADDRESS_ADC1      0x02000010
#define SIS3302_ACTUAL_NEXT_SAMPLE_ADDRESS_ADC2      0x02000014
#define SIS3302_ACTUAL_NEXT_SAMPLE_ADDRESS_ADC3      0x02800010
#define SIS3302_ACTUAL_NEXT_SAMPLE_ADDRESS_ADC4      0x02800014
#define SIS3302_ACTUAL_NEXT_SAMPLE_ADDRESS_ADC5      0x03000010
#define SIS3302_ACTUAL_NEXT_SAMPLE_ADDRESS_ADC6      0x03000014
#define SIS3302_ACTUAL_NEXT_SAMPLE_ADDRESS_ADC7      0x03800010
#define SIS3302_ACTUAL_NEXT_SAMPLE_ADDRESS_ADC8      0x03800014
```

These 8 read only registers hold the current next sampling address for the given channel.

Note: the Next Sample Address points to 16-bit words (samples).

Bit	Function
31	unused, read as 0
...	
25	unused, read as 0
24	Next Sample Address Bit 24 (Bank flag)
..	
2	Next Sample Address Bit 2
1	Next Sample Address Bit 1*
0	Next Sample Address Bit 0*

* Sample address bits 1 and 0 are always “0”.

Data are stored to memory in packets of 4 consecutive samples by the sample logic.

4.26 ADC1-8 Previous Bank Sample address register

```
#define SIS3302_PREVIOUS_BANK_SAMPLE_ADDRESS_ADC1    0x02000018
#define SIS3302_PREVIOUS_BANK_SAMPLE_ADDRESS_ADC2    0x0200001C
#define SIS3302_PREVIOUS_BANK_SAMPLE_ADDRESS_ADC3    0x02800018
#define SIS3302_PREVIOUS_BANK_SAMPLE_ADDRESS_ADC4    0x0280001C
#define SIS3302_PREVIOUS_BANK_SAMPLE_ADDRESS_ADC5    0x03000018
#define SIS3302_PREVIOUS_BANK_SAMPLE_ADDRESS_ADC6    0x0300001C
#define SIS3302_PREVIOUS_BANK_SAMPLE_ADDRESS_ADC7    0x03800018
#define SIS3302_PREVIOUS_BANK_SAMPLE_ADDRESS_ADC8    0x0380001C
```

These 8 read only registers hold the stored next sampling address of the previous bank. It is the stop address + 1;

Note: the Next Sample Address points to 16-bit words (samples).

Bit	Function
31	unused, read as 0
...	
25	unused, read as 0
24	Next Sample Address Bit 24 (Bank flag)
..	
2	Next Sample Address Bit 2
1	Next Sample Address Bit 1*
0	Next Sample Address Bit 0*

4.27 Actual Sample registers

```
#define SIS3302_ACTUAL_SAMPLE_VALUE_ADC12      0x02000020
#define SIS3302_ACTUAL_SAMPLE_VALUE_ADC34      0x02800020
#define SIS3302_ACTUAL_SAMPLE_VALUE_ADC56      0x03000020
#define SIS3302_ACTUAL_SAMPLE_VALUE_ADC56      0x03000020
```

Read “on the fly” of the actual converted ADC values.

The read only registers are updated with every ADC clock, unless a concurrent VME read access is pending.

The register contents is refreshed and can be read any time (i.e. they are updated independent of the unarmed, armed, sampling state) as long as a sampling clock is distributed on the ADC board (internal clock or active/clocking external clock)

ADC 1 / 3 / 5 / 7	ADC 2 / 4 / 6 / 8
D31:16	D15:0
16-bit data	16-bit data

4.28 Trigger Setup registers

```
#define SIS3302_TRIGGER_SETUP_ADC1      0x02000030
#define SIS3302_TRIGGER_SETUP_ADC2      0x02000038
#define SIS3302_TRIGGER_SETUP_ADC3      0x02800030
#define SIS3302_TRIGGER_SETUP_ADC4      0x02800038
#define SIS3302_TRIGGER_SETUP_ADC5      0x03000030
#define SIS3302_TRIGGER_SETUP_ADC6      0x03000038
#define SIS3302_TRIGGER_SETUP_ADC7      0x03800030
#define SIS3302_TRIGGER_SETUP_ADC8      0x03800038
```

These read/write registers hold the (lower) Peaking and Gap Time values of the trapezoidal FIR filter, Trigger Pulse Length value and Internal Gate Length value.

(Flat Time = SumG time – Peaking Time)

Bit	Function		
31	Reserved	Internal Gate Length (max. 63 clocks)	
30	Reserved		
29	Internal Gate Length bit 5		
28	Internal Gate Length bit 4		
27	Internal Gate Length bit 3		
26	Internal Gate Length bit 2		
25	Internal Gate Length bit 1		
24	Internal Gate Length bit 0		
23	Pulse Length bit 7	Internal Trigger Pulse Length (max. 255 clocks)	
22	Pulse Length bit 6		
21	Pulse Length bit 5		
20	Pulse Length bit 4		
19	Pulse Length bit 3		
18	Pulse Length bit 2		
17	Pulse Length bit 1		
16	Pulse Length bit 0		
15	SumG bit 7	SumG time (time between both sums)	
14	SumG bit 6		
13	SumG bit 5		
12	SumG bit 4		
11	SumG bit 3		Note: definition of SumG bit 8 can be found in "Trigger Extended Setup registers".
10	SumG bit 2		
9	SumG bit 1		
8	SumG bit 0		
7	P bit 7	P : Peaking time $x+P$ $\sum_{i=x} S_i$	
6	P bit 6		
5	P bit 5		
4	P bit 4		
3	P bit 3		
2	P bit 2		
1	P bit 1		Note: definition of P bit 8 can be found in "Trigger Extended Setup registers".
0	P bit 0		

The power up default value reads 0x0

- Si:** Sum of ADC input sample stream from x to x+P
- P:** Peaking time (number of values to sum)
- SumG:** SumGap time (distance in clock ticks of the two running sums)

4.29 Trigger Extended Setup registers

```
#define SIS3302_TRIGGER_EXTENTED_SETUP_ADC1      0x02000078
#define SIS3302_TRIGGER_EXTENTED_SETUP_ADC2      0x0200007C
#define SIS3302_TRIGGER_EXTENTED_SETUP_ADC3      0x02800078
#define SIS3302_TRIGGER_EXTENTED_SETUP_ADC4      0x0280007C
#define SIS3302_TRIGGER_EXTENTED_SETUP_ADC5      0x03000078
#define SIS3302_TRIGGER_EXTENTED_SETUP_ADC6      0x0300007C
#define SIS3302_TRIGGER_EXTENTED_SETUP_ADC7      0x03800078
#define SIS3302_TRIGGER_EXTENTED_SETUP_ADC8      0x0380007C
```

These read/write registers hold the (upper) Peaking and Gap Time values of the trapezoidal FIR filter, the decimation value and Internal Trigger Delay value.

Bit	Function	
31	Reserved	Internal Trigger Delay (max. 31 clocks)
30	Reserved	
29	Reserved	
28	Internal Trigger Delay	
27	Internal Trigger Delay	
26	Internal Trigger Delay	
25	Internal Trigger Delay	
24	Internal Trigger Delay	SumG time (time between both sums)
23	Reserved	
22	Reserved	
21	Reserved	
20	Reserved	
19	Reserved	
18	Trigger Decimation Mode bit 2	
17	Trigger Decimation Mode bit 1	
16	Trigger Decimation Mode bit 0	P : Peaking time
15	Reserved	
14	Reserved	
13	Reserved	
12	Reserved	
11	Reserved	
10	Reserved	
9	Reserved	
8	SumG bit 8	
7	Reserved	
6	Reserved	
5	Reserved	
4	Reserved	
3	Reserved	
2	Reserved	
1	Reserved	
0	P bit 8	

The power up default value reads 0x0

Note:

The maximum SumG time: 511 (clocks)

The minimum SumG time: 1 (clocks)

Value = 0 will be set to 1

The maximum Peaking time: 511 (clocks)

The minimum Peaking time: 1 (clocks)

Value = 0 will be set to 1

Trigger Decimation Mode bit setting table:

Bit2	Bit1	Bit0	Trigger Decimation (in clocks)
0	0	0	1 (no decimation)
0	0	1	2 clocks
0	1	0	4 clocks
0	1	1	8 clocks
1	0	0	16 clocks
1	0	1	reserved
1	1	0	reserved
1	1	1	reserved

Only the Peaking and Gap Time dependent on the Trigger Decimation Mode !

4.30 Trigger Threshold registers

```

#define SIS3302_TRIGGER_THRESHOLD_ADC1      0x02000034
#define SIS3302_TRIGGER_THRESHOLD_ADC2      0x0200003C
#define SIS3302_TRIGGER_THRESHOLD_ADC3      0x02800034
#define SIS3302_TRIGGER_THRESHOLD_ADC4      0x0280003C
#define SIS3302_TRIGGER_THRESHOLD_ADC5      0x03000034
#define SIS3302_TRIGGER_THRESHOLD_ADC6      0x0300003C
#define SIS3302_TRIGGER_THRESHOLD_ADC7      0x03800034
#define SIS3302_TRIGGER_THRESHOLD_ADC8      0x0380003C

```

These read/write registers hold the threshold values for the ADC channels.

Bit	31-27	26	25	24	23	22-17	16-0
Function	none	Disable Trigger Out	Trigger Mode GT	none	Extended Threshold Mode	none	Trapezoidal threshold value

default after Reset: 0x0

The value of the Sum (trapezoidal value) depends on the peaking time P. Therefore the selection of the value of the Trapezoidal threshold depends on P also.

The running sum is build with full accuracy.

- Trigger Extended Mode is cleared:
a shifted 16-bit running sum + 0x1 0000 is compared with the threshold value of the Trigger Threshold register.
- Trigger Extended Mode is set:
the full 25-bit running sum + 0x200 0000 is compared with the value of the Trigger Extended Threshold register to generate the Trigger.
- GT is set:
the Trigger Out Pulse will be issued if the actual trapezoidal value **goes** above the programmable trapezoidal threshold value

Note 1: The trigger is disabled if GT is cleared

Note 2: use “ADCx input invert bit” for negative signals (see Event configuration registers)

4.30.1 Extended Threshold Mode = 0

The running sum is build with full accuracy before the result is shifted to a 16-bit wide sum value (SUM1). SUM2 is SUM1 delayed by G clocks.

if P = 1 to 15: 25 bit running sum is shifted to the right by 4 (N)
 if P = 16 to 31: 25 bit running sum is shifted to the right by 5
 if P = 32 to 63: 25 bit running sum is shifted to the right by 6
 if P = 64 to 127: 25 bit running sum is shifted to the right by 7
 if P = 128 to 255: 25 bit running sum is shifted to the right by 8
 if P = 256 to 511: 25 bit running sum is shifted to the right by 9

See “int calculateFirTriggerAdcCounts (void)” in sis3302_configuraton.c and Trigger Example.

Trapezoidal value calculation:

Trapezoidal value = (SUM2 – SUM1) + 0x10000

Where

$$\text{SUM1} = \text{shift right by } N \left(\sum_{i=x}^{x+P} S_i \right)$$

$$\text{SUM2} = \text{shift right by } N \left(\sum_{j=x+\text{sumG}}^{x+P+\text{sumG}} S_j \right)$$

The FIR Filter logic adds 0x10000 to the result of the subtraction of the two running sums. This implies, that the internal value of the trapezoid is on average 0x10000.

A Trigger Output pulse is generated if the Trapezoidal value exceeds the trigger threshold value.

4.30.2 Extended Threshold Mode = 1

The FIR Filter logic adds 0x200 0000 to the result of the subtraction of the two running 25-bit sums. This implies, that the internal value of the trapezoid is on average 0x200 0000.

Trapezoidal value = (SUM2 – SUM1) + 0x200 0000

A Trigger Output pulse is generated if the 26-bit Trapezoidal value exceeds the trigger extended threshold value.

4.30.3 Trigger example

Screen shot 1 below shows a triggered signal on ADC channel 1 and the resulting FIR. The Peaking Time P is set to 10 and sumG Time is set to 16 (Flat Time = 6).

The trigger condition is set to GT, the trapezoidal trigger threshold is set to 100 (trigger threshold reg = 0x10000 + 100), what results in a decimal threshold of 160 ADC counts.

Trigger Threshold = 100 -> $((100 * 16) / 10) = 160$ adc counts (corresponds to approx. 5mV)
 - * 16: because data are shifted right by 4
 - / 10: because P = 10 (sum over 10 counts)

ADC Raw data: (36481 – 34936 = 1545 corresponds to 50mV) .

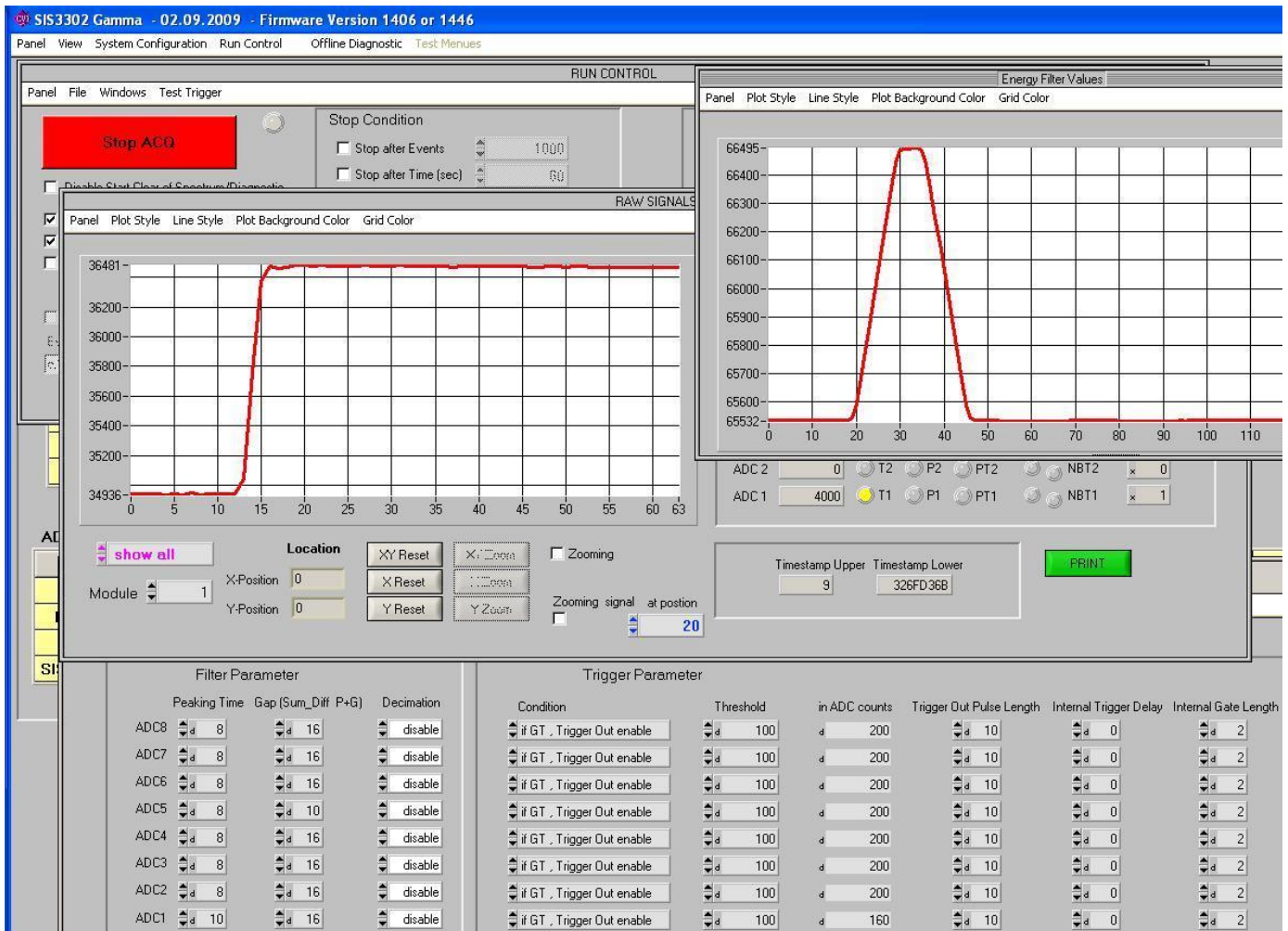

Screen shot 1

Peaking Time = 10
SumG Time = 16
Gap Time = 6

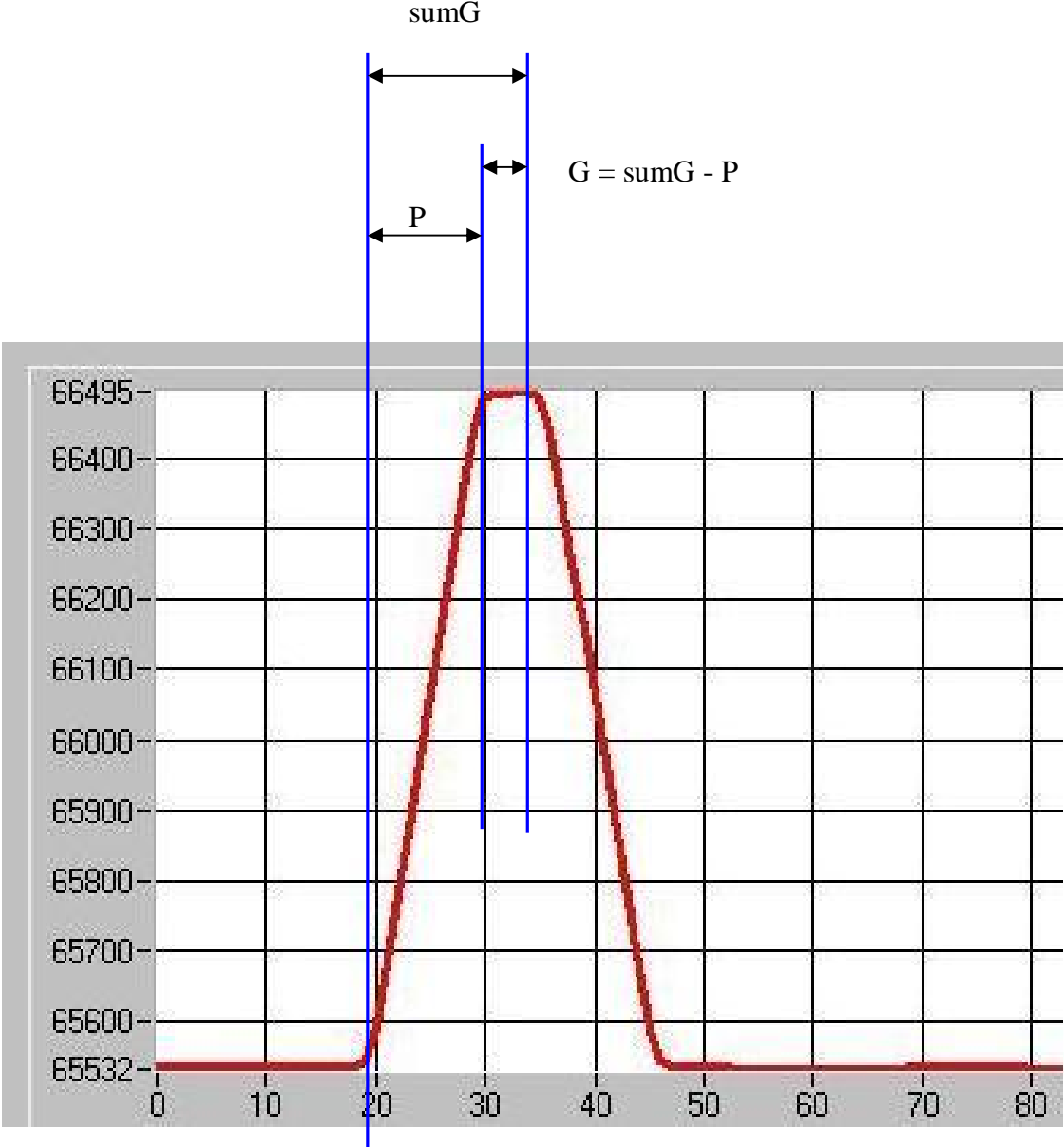

Screen shot 2

4.31 Trigger Extended Threshold registers

```

#define SIS3302_TRIGGER_THRESHOLD_ADC1      0x020000A0
#define SIS3302_TRIGGER_THRESHOLD_ADC2      0x020000A4
#define SIS3302_TRIGGER_THRESHOLD_ADC3      0x028000A0
#define SIS3302_TRIGGER_THRESHOLD_ADC4      0x028000A4
#define SIS3302_TRIGGER_THRESHOLD_ADC5      0x030000A0
#define SIS3302_TRIGGER_THRESHOLD_ADC6      0x030000A4
#define SIS3302_TRIGGER_THRESHOLD_ADC7      0x038000A0
#define SIS3302_TRIGGER_THRESHOLD_ADC8      0x038000A4

```

These read/write registers hold the extended threshold values for the ADC channels.

Bit	31-26	25-0
Function	none	Trapezoidal Extended threshold value

default after Reset: 0x0

4.32 Energy Setup GP registers

```
#define SIS3302_ENERGY_SETUP_GP_ALL_ADC          0x01000040

#define SIS3302_ENERGY_SETUP_GP_ADC12          0x02000040
#define SIS3302_ENERGY_SETUP_GP_ADC34          0x02800040
#define SIS3302_ENERGY_SETUP_GP_ADC56          0x03000040
#define SIS3302_ENERGY_SETUP_GP_ADC78          0x03800040
```

This read/write register holds the Decimation, Peaking (max. 1023) and Gap (max. 255) Time values of the trapezoidal FIR Energy filter.

Bit		
31	reserved	
30	Extra Filter	
29	Decimation mode bit 1	
28	Decimation mode bit 0	
27	reserved	
26	reserved	
25	reserved	
24	reserved	
23	reserved	Peaking time P bits 9 to 8
..	..	
17	Peaking Time bit 9	
16	Peaking Time bit 8	
15	Gap Time bit 7	Gap time (time between both sums)
..	..	
..	..	
8	Gap Time bit 0	
7	Peaking Time bit 7	Peaking time P bits 7 to 0 $\sum_{i=x}^{x+P} S_i$
..	..	
..	..	
0	Peaking Time bit 0	

The power up default value reads 0x 00000000

Decimation Mode bit setting table:

Bit1	Bit0	Decimation (in clocks)
0	0	1 (no decimation)
0	1	2 clocks
1	0	4 clocks
1	1	8 clocks

4.33 Energy Gate Length registers

```
#define SIS3302_ENERGY_GATE_LENGTH_ALL_ADC          0x01000044

#define SIS3302_ENERGY_GATE_LENGTH_ADC12          0x02000044
#define SIS3302_ENERGY_GATE_LENGTH_ADC34          0x02800044
#define SIS3302_ENERGY_GATE_LENGTH_ADC56          0x03000044
#define SIS3302_ENERGY_GATE_LENGTH_ADC78          0x03800044
```

This 17-bit register (bits 16:0) defines the length of the energy gate and defines test modes (bits 29:28) of the Energy Data. The Energy Gate starts with begin of sampling and stops after (“value” * decimation factor) clocks.

Bits	31-30	29-28	27-17	16 :0
Function	0	Test Mode bits[1 :0]	0	Energy Gate Length

Test Mode bit setting table:

Bit1	Bit0	meaning of ADC Energy Data
0	0	Energy MWD-MA, Trapez
0	1	Energy MW-MA, Trapez (test mode)
1	0	Trigger Trapez (test mode)
1	1	reserved

Test Mode: Trigger Trapez

The Trigger Trapez is delayed by 32 clocks and it is stored with the Energy Decimation factor !!!

4.34 Energy Sample registers

This register set (ENERGY_SAMPLE_LENGTH, ENERGY_SAMPLE_START_INDEX1, ENERGY_SAMPLE_START_INDEX2 and ENERGY_SAMPLE_START_INDEX3) controls the storage of the energy filter values.

While the Energy Gate is active the logic compares the value of the Energy Gate Index (an internal counter, which is cleared at the beginning of the event and incremented by each decimated clock) with the values of the “ENERGY_SAMPLE_START_INDEX” registers. If the result of the compare is equal then the logic writes N values (“ENERGY_SAMPLE_LENGTH”) into the Energy Buffer.

The number of values is limited to 510 values in total !

4.34.1 Energy Sample Length registers

```
#define SIS3302_ENERGY_SAMPLE_LENGTH_ALL_ADC      0x01000048
#define SIS3302_ENERGY_SAMPLE_LENGTH_ADC12      0x02000048
#define SIS3302_ENERGY_SAMPLE_LENGTH_ADC34      0x02800048
#define SIS3302_ENERGY_SAMPLE_LENGTH_ADC56      0x03000048
#define SIS3302_ENERGY_SAMPLE_LENGTH_ADC78      0x03800048
```

Bits	31-11	10 :0
Function	0	Energy Sample Length valid values : 0,2,4,508, 510

4.34.2 Energy Sample Start Index1 registers

```
#define SIS3302_ENERGY_SAMPLE_START_INDEX1_ALL_ADC 0x0100004C
#define SIS3302_ENERGY_SAMPLE_START_INDEX1_ADC12 0x0200004C
#define SIS3302_ENERGY_SAMPLE_START_INDEX1_ADC34 0x0280004C
#define SIS3302_ENERGY_SAMPLE_START_INDEX1_ADC56 0x0300004C
#define SIS3302_ENERGY_SAMPLE_START_INDEX1_ADC78 0x0380004C
```

Bits	31-16	15 :0
Function	0	Energy Sample Start Index1

Energy Sample Start Index1 = 0 : disable Start

4.34.3 Energy Sample Start Index2 registers

```
#define SIS3302_ENERGY_SAMPLE_START_INDEX2_ALL_ADC 0x01000050
#define SIS3302_ENERGY_SAMPLE_START_INDEX2_ADC12 0x02000050
#define SIS3302_ENERGY_SAMPLE_START_INDEX2_ADC34 0x02800050
#define SIS3302_ENERGY_SAMPLE_START_INDEX2_ADC56 0x03000050
#define SIS3302_ENERGY_SAMPLE_START_INDEX2_ADC78 0x03800050
```

Bits	31-16	15 :0
Function	0	Energy Sample Start Index2

Energy Sample Start Index2 = 0 : disable Start

4.34.4 Energy Sample Start Index3 registers

```
#define SIS3302_ENERGY_SAMPLE_START_INDEX3_ALL_ADC 0x01000054
#define SIS3302_ENERGY_SAMPLE_START_INDEX3_ADC12 0x02000054
#define SIS3302_ENERGY_SAMPLE_START_INDEX3_ADC34 0x02800054
#define SIS3302_ENERGY_SAMPLE_START_INDEX3_ADC56 0x03000054
#define SIS3302_ENERGY_SAMPLE_START_INDEX3_ADC78 0x03800054
```

Bits	31-16	15 :0
Function	0	Energy Sample Start Index3

Energy Sample Start Index3 = 0 : disable Start

4.35 Energy Tau Factor registers

```

#define SIS3302_ENERGY_TAU_FACTOR_ADC1357      0x01000058
#define SIS3302_ENERGY_TAU_FACTOR_ADC2468      0x0100005C

#define SIS3302_ENERGY_TAU_FACTOR_ADC1         0x02000058
#define SIS3302_ENERGY_TAU_FACTOR_ADC2         0x0200005C
#define SIS3302_ENERGY_TAU_FACTOR_ADC3         0x02800058
#define SIS3302_ENERGY_TAU_FACTOR_ADC4         0x0280005C
#define SIS3302_ENERGY_TAU_FACTOR_ADC5         0x03000058
#define SIS3302_ENERGY_TAU_FACTOR_ADC6         0x0300005C
#define SIS3302_ENERGY_TAU_FACTOR_ADC7         0x03800058
#define SIS3302_ENERGY_TAU_FACTOR_ADC8         0x0380005C

```

Those registers hold the 6-bit wide Tau factor for the corresponding ADC .
They are implemented on the FPGA group level also what allows you to run all 8 channels on the board with individual Tau settings.

Bit	Function
31	unused
...	...
6	unused
5	Bit 5 of Tau factor
...	...
0	Bit 0 of Tau factor

The decay time depends on the Tau factor, on the decimation mode and on the sample clock :

```

switch (gl_uint_SIS3302ClockModeConf) {
    case 0: // intern 100 MHz
        *sample_clock = 100000 ;           //
        break;
    case 1: // intern 50 MHz
        *sample_clock = 50000 ;           //
        break;
    .....
} // end switch (gl_uint_SIS3302ClockModeConf)

switch (gl_uint_FirDecimationMode) {
    case 0: // no decimation
        float_sampling_time_us = 1000.0/sample_clock ;
        break;
    case 1: //
        float_sampling_time_us = 2000.0/sample_clock ;
        break;
    case 2: //
        float_sampling_time_us = 4000.0/sample_clock ;
        break;
    case 3: //
        float_sampling_time_us = 8000.0/sample_clock ;
        break;
} // end switch (gl_uint_FirDecimationMode)

float_decay_factor = (Tau factor / 32768.0 ) ;
float_decay_time_us = -(float_sampling_time_us / (log(1.0-float_decay_factor)));

```

Example: 100 MHz; Decimation = 4

```
Tau Factor = 1      decay_time_us = 1310.69999990 us
Tau Factor = 2      decay_time_us = 655.339999980 us
Tau Factor = 3      decay_time_us = 436.886666636 us
Tau Factor = 4      decay_time_us = 327.659999959 us
Tau Factor = 5      decay_time_us = 262.123999949 us
Tau Factor = 6      decay_time_us = 218.43333272 us
Tau Factor = 7      decay_time_us = 187.22571357 us
Tau Factor = 8      decay_time_us = 163.819999919 us
Tau Factor = 9      decay_time_us = 145.61555464 us
Tau Factor = 10     decay_time_us = 131.05199898 us
Tau Factor = 11     decay_time_us = 119.13636252 us
Tau Factor = 12     decay_time_us = 109.20666545 us
Tau Factor = 13     decay_time_us = 100.80461406 us
Tau Factor = 14     decay_time_us = 93.60285572 us
Tau Factor = 15     decay_time_us = 87.36133181 us
Tau Factor = 16     decay_time_us = 81.89999837 us
Tau Factor = 17     decay_time_us = 77.08117474 us
Tau Factor = 18     decay_time_us = 72.79777595 us
Tau Factor = 19     decay_time_us = 68.96526122 us
Tau Factor = 20     decay_time_us = 65.51599796 us
Tau Factor = 21     decay_time_us = 62.39523596 us
Tau Factor = 22     decay_time_us = 59.55817958 us
Tau Factor = 23     decay_time_us = 56.96782375 us
Tau Factor = 24     decay_time_us = 54.59333089 us
Tau Factor = 25     decay_time_us = 52.40879746 us
Tau Factor = 26     decay_time_us = 50.39230505 us
Tau Factor = 27     decay_time_us = 48.52518244 us
Tau Factor = 28     decay_time_us = 46.79142572 us
Tau Factor = 29     decay_time_us = 45.17723843 us
Tau Factor = 30     decay_time_us = 43.67066361 us
Tau Factor = 31     decay_time_us = 42.26128717 us
Tau Factor = 32     decay_time_us = 40.93999674 us
Tau Factor = 33     decay_time_us = 39.69878452 us
Tau Factor = 34     decay_time_us = 38.53058477 us
Tau Factor = 35     decay_time_us = 37.42913929 us
Tau Factor = 36     decay_time_us = 36.38888522 us
Tau Factor = 37     decay_time_us = 35.40486110 us
Tau Factor = 38     decay_time_us = 34.47262771 us
Tau Factor = 39     decay_time_us = 33.58820116 us
Tau Factor = 40     decay_time_us = 32.74799593 us
Tau Factor = 41     decay_time_us = 31.94877631 us
Tau Factor = 42     decay_time_us = 31.18761477 us
Tau Factor = 43     decay_time_us = 30.46185609 us
Tau Factor = 44     decay_time_us = 29.76908643 us
Tau Factor = 45     decay_time_us = 29.10710653 us
Tau Factor = 46     decay_time_us = 28.47390836 us
Tau Factor = 47     decay_time_us = 27.86765479 us
Tau Factor = 48     decay_time_us = 27.28666178 us
Tau Factor = 49     decay_time_us = 26.72938277 us
Tau Factor = 50     decay_time_us = 26.19439491 us
Tau Factor = 51     decay_time_us = 25.68038696 us
Tau Factor = 52     decay_time_us = 25.18614855 us
Tau Factor = 53     decay_time_us = 24.71056064 us
Tau Factor = 54     decay_time_us = 24.25258709 us
Tau Factor = 55     decay_time_us = 23.81126713 us
Tau Factor = 56     decay_time_us = 23.38570858 us
Tau Factor = 57     decay_time_us = 22.97508192 us
Tau Factor = 58     decay_time_us = 22.57861478 us
Tau Factor = 59     decay_time_us = 22.19558721 us
Tau Factor = 60     decay_time_us = 21.82532722 us
Tau Factor = 61     decay_time_us = 21.46720690 us
Tau Factor = 62     decay_time_us = 21.12063885 us
Tau Factor = 63     decay_time_us = 20.78507295 us
```

4.36 MCA ENERGY_to_Histogram Calculation Parameter register

```

#define SIS3302_MCA_ENERGY2HISTOGRAM_PARAM_ADC1357      0x01000060
#define SIS3302_MCA_ENERGY2HISTOGRAM_PARAM_ADC2468      0x01000064

#define SIS3302_MCA_ENERGY2HISTOGRAM_PARAM_ADC1         0x02000060
#define SIS3302_MCA_ENERGY2HISTOGRAM_PARAM_ADC3         0x02800060
#define SIS3302_MCA_ENERGY2HISTOGRAM_PARAM_ADC5         0x02000060
#define SIS3302_MCA_ENERGY2HISTOGRAM_PARAM_ADC7         0x03800060

#define SIS3302_MCA_ENERGY2HISTOGRAM_PARAM_ADC2         0x02000064
#define SIS3302_MCA_ENERGY2HISTOGRAM_PARAM_ADC4         0x02800064
#define SIS3302_MCA_ENERGY2HISTOGRAM_PARAM_ADC6         0x02000064
#define SIS3302_MCA_ENERGY2HISTOGRAM_PARAM_ADC8         0x03800064
  
```

D31:28	D27:20	D19:0
N (Energy 2 ^N Divider)	Energy Multiplier Enable bits	Energy Subtract Offset

Calculation of the Histogram Index:

```

Multiplied_Energy =   bit 27 * (Energy>>1)
                      + bit 26 * (Energy>>2)
                      + bit 25 * (Energy>>3)
                      + bit 24 * (Energy>>4)
                      + bit 23 * (Energy>>5)
                      + bit 22 * (Energy>>6)
                      + bit 21 * (Energy>>7)
                      + bit 20 * (Energy>>8)
  
```

Histogram_index = (Multiplied_Energy>>(N-1) - Subtract Offset

Note: N = 0 -> not allowed !

Example :

Signal 100mV → 3000 counts with Peakttime = 100 → Energy Value = 300.000 (0x493e0)

MCA_ENERGY2HISTOGRAM_PARAM = 0x 9 A4 00100

```

Multiplied_Energy =   bit 27 * (Energy>>1)
                      + bit 25 * (Energy>>3)
                      + bit 22 * (Energy>>6)
  
```

= 0x249F0 + 0x927C + 0x124F

= 0x2EEBB

Histogram_index = (0x2EEBB >> 8) - 0x100

= 0x2EE - 0x100

= 0x1EE

= 494

Calculation of the Energy to Histogram Index Factor:

```
int MCA_Energy_to_Histogram_factor_calculation (void)
{
unsigned int i;
int temp;
unsigned int value, div, multi, subtract;
double multiplier_factor1, multiplier_factor2 ;

// Energy to Histogram calculation parameters
div      = (gl_uint_McaEnergy2HistogramParameter >> 28) & 0xf ;
multi    = (gl_uint_McaEnergy2HistogramParameter >> 20) & 0xff ;
subtract = (gl_uint_McaEnergy2HistogramParameter ) & 0xffff ;

multiplier_factor1 = 1.0 ;
if (div != 0) {
    //multiplier_factor1 = multiplier_factor / pow(2,div) ;
    multiplier_factor1 = 0.0 ;
    for (i=0;i<8;i++) {
        temp = ((multi >> (8-i)) & 0x1 ) ;
        if (temp == 1) {
            multiplier_factor2 = 1.0 / pow(2,i) ;
            multiplier_factor1 = multiplier_factor1
                + multiplier_factor2 ;
        }
    }
    multiplier_factor1 = multiplier_factor1 / pow(2,(div-1)) ; ;
}

SetCtrlVal (Panels[RUN_MCA_MENU], RUN_MCA_RUN_MCA_FACTOR, multiplier_factor1);

return 0;
}
```

4.37 MCA Histogram Parameter register

```
#define SIS3302_MCA_HISTOGRAM_PARAM_ALL_ADC      0x01000068

#define SIS3302_MCA_HISTOGRAM_PARAM_ADC12      0x02000068
#define SIS3302_MCA_HISTOGRAM_PARAM_ADC34      0x02800068
#define SIS3302_MCA_HISTOGRAM_PARAM_AD56      0x03000068
#define SIS3302_MCA_HISTOGRAM_PARAM_ADC78      0x03800068
```

Bit	Write Function	Read Function
31	None	0
..
8	None	0
7	Memory Write Test Mode	Memory Write Test Mode
6	None	0
5	MCA ADC2,4,6,8 histogramming Enable bit	MCA ADC2,4,6,8 histogramming Enable bit
4	MCA ADC1,3,5,7 histogramming Enable bit	MCA ADC1,3,5,7 histogramming Enable bit
3	Pileup Enable bit	Pileup Enable bit
2	None	0
1	Histogram Size bit 1	Histogram Size bit 1
0	Histogram Size bit 0	Histogram Size bit 0

The power up default value is 0

Histogram Size bit:

bit 1	bit 0	Histogram Size
0	0	1K (1024)
0	1	2K
1	0	4K
1	1	8K

Pileup Enable bit = 0: don't increment histogram in case of pileup

Pileup Enable bit = 1: increment histogram in case of pileup

Memory Write Test Mode = 1: Test Write to the Memory with BLT32 is possible.
(start must on 8-byte boundary address and the length must be Nx8 byte)

MCA ADCx histogramming Enable bit:

If this bit is set then the ADC value will be histogrammed in MCA mode.

To map the full 16-bit ADC range to the histogram page you will want to use the value listed in the table below.

Histogram Size	MCA ENERGY_to_Histogram Calculation Parameter
1K (1024)	0x68000000
2K	0x58000000
4K	0x48000000
8K	0x38000000

4.38 MCA Trigger Start counter register

```
#define SIS3302_MCA_TRIGGER_START_COUNTER_ADC1      0x02000080
#define SIS3302_MCA_TRIGGER_START_COUNTER_ADC2      0x02000090
#define SIS3302_MCA_TRIGGER_START_COUNTER_ADC3      0x02800080
#define SIS3302_MCA_TRIGGER_START_COUNTER_ADC4      0x02800090
#define SIS3302_MCA_TRIGGER_START_COUNTER_ADC5      0x03000080
#define SIS3302_MCA_TRIGGER_START_COUNTER_ADC6      0x03000090
#define SIS3302_MCA_TRIGGER_START_COUNTER_ADC7      0x03800080
#define SIS3302_MCA_TRIGGER_START_COUNTER_ADC8      0x03800090
```

This 32-bit counter is cleared with a Multiscan or Scan operation start command. During the Multiscan or Scan operation is active each Trigger Start (Start of the Energy Window) increments this counter.

4.39 MCA Pileup counter register

```
#define SIS3302_MCA_PILEUP_COUNTER_ADC1             0x02000084
#define SIS3302_MCA_PILEUP_COUNTER_ADC2             0x02000094
#define SIS3302_MCA_PILEUP_COUNTER_ADC3             0x02800084
#define SIS3302_MCA_PILEUP_COUNTER_ADC4             0x02800094
#define SIS3302_MCA_PILEUP_COUNTER_ADC5             0x03000084
#define SIS3302_MCA_PILEUP_COUNTER_ADC6             0x03000094
#define SIS3302_MCA_PILEUP_COUNTER_ADC7             0x03800084
#define SIS3302_MCA_PILEUP_COUNTER_ADC8             0x03800094
```

This 32-bit counter is cleared with a Multiscan or Scan operation start command. During the Multiscan or Scan operation is active a detected Pileup (Pileup or Retrigger Pileup) increments this counter.

4.40 MCA ENERGY_to_High counter register

```
#define SIS3302_MCA_ENERGY2HIGH_COUNTER_ADC1      0x02000088
#define SIS3302_MCA_ENERGY2HIGH_COUNTER_ADC2      0x02000098
#define SIS3302_MCA_ENERGY2HIGH_COUNTER_ADC3      0x02800088
#define SIS3302_MCA_ENERGY2HIGH_COUNTER_ADC4      0x02800098
#define SIS3302_MCA_ENERGY2HIGH_COUNTER_ADC5      0x03000088
#define SIS3302_MCA_ENERGY2HIGH_COUNTER_ADC6      0x03000098
#define SIS3302_MCA_ENERGY2HIGH_COUNTER_ADC7      0x03800088
#define SIS3302_MCA_ENERGY2HIGH_COUNTER_ADC8      0x03800098

#define SIS3302_MCA_ENERGY2LOW_COUNTER_ADC1        0x0200008C
```

This 32-bit counter is cleared with a Multiscan or Scan operation start command. During the Multiscan or Scan operation is active this counter will be incremented if the calculated Histogram Index is higher than the histogram size.

4.41 MCA ENERGY_to_Low counter register

```
#define SIS3302_MCA_ENERGY2LOW_COUNTER_ADC1        0x0200008C
#define SIS3302_MCA_ENERGY2LOW_COUNTER_ADC2        0x0200009C
#define SIS3302_MCA_ENERGY2LOW_COUNTER_ADC3        0x0280008C
#define SIS3302_MCA_ENERGY2LOW_COUNTER_ADC4        0x0280009C
#define SIS3302_MCA_ENERGY2LOW_COUNTER_ADC5        0x0300008C
#define SIS3302_MCA_ENERGY2LOW_COUNTER_ADC6        0x0300009C
#define SIS3302_MCA_ENERGY2LOW_COUNTER_ADC7        0x0380008C
#define SIS3302_MCA_ENERGY2LOW_COUNTER_ADC8        0x0380009C
```

This 32-bit counter is cleared with a Multiscan or Scan operation start command. During the Multiscan or Scan operation is active this counter will be incremented if the calculated Histogram Index is negative.

4.42 ADC memory

```
#define SIS3302_ADC1_OFFSET 0x04000000
#define SIS3302_ADC2_OFFSET 0x04800000
#define SIS3302_ADC3_OFFSET 0x05000000
#define SIS3302_ADC4_OFFSET 0x05800000
#define SIS3302_ADC5_OFFSET 0x06000000
#define SIS3302_ADC6_OFFSET 0x06800000
#define SIS3302_ADC7_OFFSET 0x07000000
#define SIS3302_ADC8_OFFSET 0x07800000
```

The 64 MByte ADC memory per channel can be address in pages of 8 MByte. The page is selected with the ADC Memory page register. One 32-bit word holds 2 ADC samples as shown in the table below.

4.42.1 Event Buffer Data Format (with MCA Mode = 0)

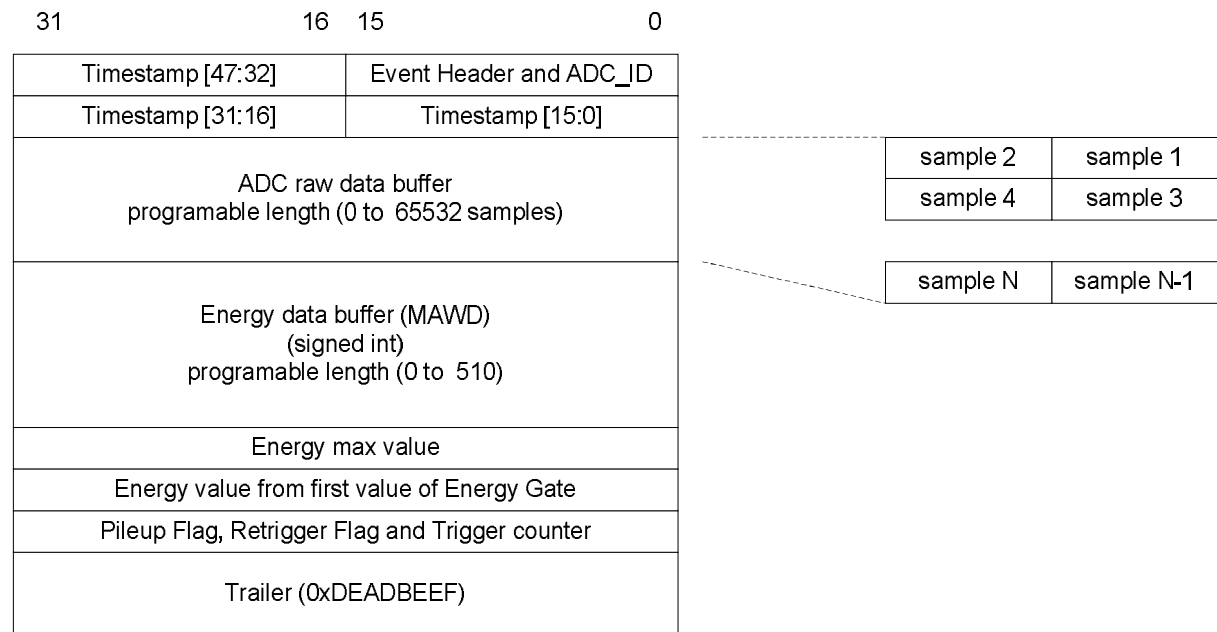

Event Header: see Event configuration registers

Pileup Flag and Trigger Counter:

Bits	31	30	29	28	27 :24	23:1	0
function	Pileup Flag	Retrigger Flag	ADC N+1 Neighbor Trigger Flag	ADC N-1 Neighbor Trigger Flag	Fast Trigger Counter	0	Trigger Flag

While the Trigger Gate is active the Trigger Counter is incremented with each delayed Trigger (up to 0xf).

- Pileup Flag is set if Fast Trigger Counter > 1
- Retrigger Flag is set if an earlier Fast Trigger was ((P+G)*Decimation) Clocks before the actual Fast Trigger. In this case the Energy Filter contains also the “Energy” of the earlier Fast Trigger.

Example:

- Raw Data Sample Length = 64
- Energy Sample Length = 280 (Start Index1 = 1; Start Index2 = 0; Start Index3 = 0)
- Energy: Peaking Time = 100 , Gap = 40, Decimation = 0

ADC_ID = 4000 upper Timestamp = 0 lower Timestamp = 2b1b45ca

```

i = 0      869c 86a1 86a2 86a3 869f 869e 86a0 86a7
i = 8      86a4 86a6 8869 8e75 91f1 9254 9247 925a
i = 16     9269 9267 926a 9267 926b 9269 9270 926a
i = 24     926c 926a 926c 9267 926e 9276 926d 926b
i = 32     926d 926c 9272 926b 926b 926f 926a 926f
i = 40     926c 9269 926d 9269 9265 926b 926b 9268
i = 48     9266 926b 9266 9264 926a 9263 9268 9262
i = 56     9263 9262 9262 9264 9264 9263 9260 9261

i = 0      11      19      18      23      20      1f      25      29
i = 8      28      34      34      3d      45      4c      52      4c
i = 16     4d      44      44      44      3e      3f      46      47
i = 24     47      217     9eb     153b    20ec    2c90    3842    4409
i = 32     4fc8     5b8b     6752    731a    7ee9    8ab8    9680    a24a
i = 40     ae18     b9ec     c5b9    d182    dd60    e929    f4f6    100c6
i = 48     10c98    1185d    12428   12ff8   13bc9   14791   15359   15f1e
i = 56     16ae4    176b5    18271   18e2b   199fa   1a5bd   1b180   1bd4e
i = 64     1c91a    1d4db    1e09f   1ec60   1f82a   203ed   20fa3   21b64
i = 72     22728    232ed    23ea0   24a5f   2561e   261de   26d9d   2795f
i = 80     28515    290d5    29c8e   2a852   2b409   2bfc6   2cb82   2d740
i = 88     2e2f3    2eeb6    2fa78   30631   311f1   31db0   32966   3351c
i = 96     340d3    34c92    35851   36408   36fc1   37b7b   38733   392e5
i = 104    39ea2    3aa65    3b61e   3c1d9   3cd94   3d951   3e509   3f0c0
i = 112    3fc78    40832    413ea   41fa8   42b66   43721   442d8   44e93
i = 120    45a55    4660e    471bc   47d6d   4891a   49302   496ea   49752
i = 128    49758    49768    4976e   49768   49761   49751   49742   4972e
i = 136    4971e    49704    49700   496f0   496e3   496ce   496bd   496a8
i = 144    49683    4966f    49660   49647   4962d   4961a   49602   495ef
i = 152    495d7    495c8    495b0   49599   4958f   49578   49567   4955f
i = 160    49554    49547    4953e   49524   49519   4950d   49338   48b59
i = 168    47ffd    4743c    4688b   45ccd   450fa   4452e   4395f   42d94
i = 176    421bf    415eb    40a10   3fe3d   3f26c   3e698   3dac1   3cef1
i = 184    3c31f    3b74e    3ab73   39fa3   393d4   387fc   37c29   37060
i = 192    36493    358c1    34cf6   34124   33555   32991   31dc8   31207
i = 200    3063f    2fa70    2eeaa   2e2ea   2d723   2cb52   2bf8a   2b3c6
i = 208    2a7f9    29c2e    29065   284a6   278e2   26d20   2615a   25595
i = 216    249d0    23e0a    2324a   22687   21abf   20f01   20343   1f78c
i = 224    1ebd3    1e016    1d459   1c8a0   1bce8   1b12e   1a56b   199a2
i = 232    18de8    1822f    1766f   16ab0   15ef4   1533f   1477f   13bc2
i = 240    1300e    1244f    11896   10cdd   1012b   f575    e9ba    de06
i = 248    d24f    c693    bad8    af26    a362    97ac    8bf6    8037
i = 256    7472    68bd    5d0f    5154    4594    39d3    2e14    2269
i = 264    16ab    afd     116    fffffd32 fffffccf fffffcce fffffcbd fffffcbb
i = 272    fffffcc5 fffffcce fffffcdd fffffce3 fffffcfa fffffd04 fffffd1d fffffd2c

```

```

max Energy = 4976e    min Energy = 11
Flags       = 1000001    trailer    = deadbeef

```

SIS3302 Gamma (27.03.2009)

Panel View System Configuration Run Control Offline Diagnostic Test Menues

Start ACQ

Disable Start Clear of Spectrum/Diagnostic

Display Raw Signals

Display FPGA Energy Filter Values

Display Energy Spectrum

Write Data to File

Event File Name
c:\sis3302_gamma_system\sis3302_gamma_system\D03-27-2009T11-43-31.dat

SIS3150USB TS Readout Loader File Name
c:\sis3302_02_adc_system\version_work\sis3150usb\data\led_test\Release\main.kdr

Stop Condition

Stop after Events 1

Stop after Time (sec) 60

READOUT_MODE

PC Single Event (only Module 1)

1 Number of Events/readout

100 max. Number of Events/readout

use max. Number of Events/readout

Energy Filter Values

Panel Plot Style Line Style Plot Background Color Grid Color

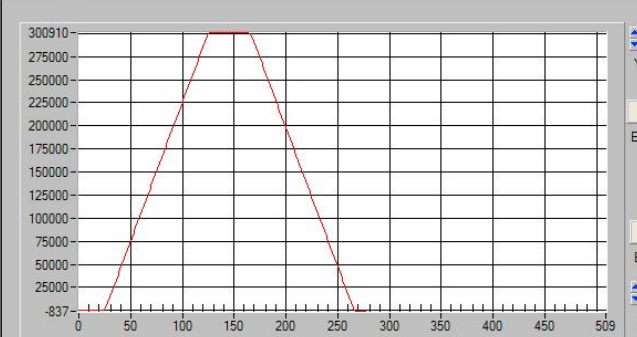

display mode
decay corrected moving average window (|)

Zooming

show all

Module 1

XY Reset XY Zoom

X Reset X Zoom

Y Reset Y Zoom

Location

X-Position 0

Y-Position 0

ADC 3 0 T3 P3 PT3 NBT3 x 0

ADC 2 0 T2 P2 PT2 NBT2 x 0

ADC 1 4000 T1 P1 PT1 NBT1 x 1

Timestamp Upper 0 Timestamp Lower 2B1B45CA

PRINT

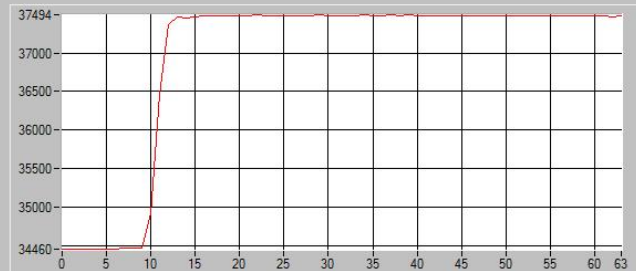

show all

Location

XY Reset XY Zoom

X Reset X Zoom

Module 1 X-Position 0

5 Modes of acquisition of current software

The current software illustrates two data acquisition modes. Single event and multi event double buffer acquisition. They can be found in sis3150_gamma_running.c as routines:

```
RunPC_SingleEventAquisition();
RunPC_SIS3302Gamma_MultiEvent_DoubleBuffer_Aquisition();
```

5.1 Single event acquisition

Events are read out one by one in single event acquisition. This mode is most straightforward to implement but not suited for throughput.

5.2 Multi Event Double Buffer acquisition

Dual bank acquisition with two memory sections of 8 MBytes each is implemented as illustrated below.

Typically events are acquired into one buffer until the end address threshold is reached. At this point in time acquisition is passed to the alternate bank/buffer with the key disarm and arm bank N command and data are readout from the inactive bank.

The key disarm and arm bank N registers position the memory pointer to the beginning of the corresponding buffer.

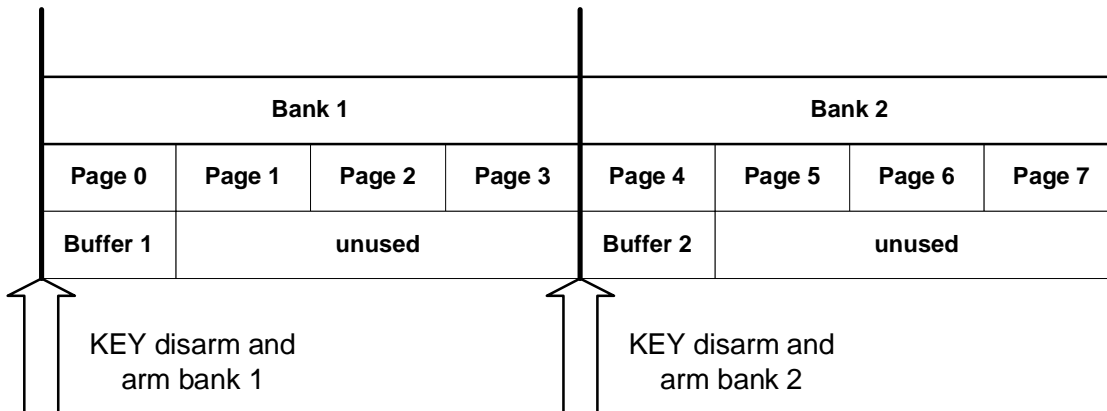

6 Board layout

A printout of the silk screen of the component side of the PCB is shown below.

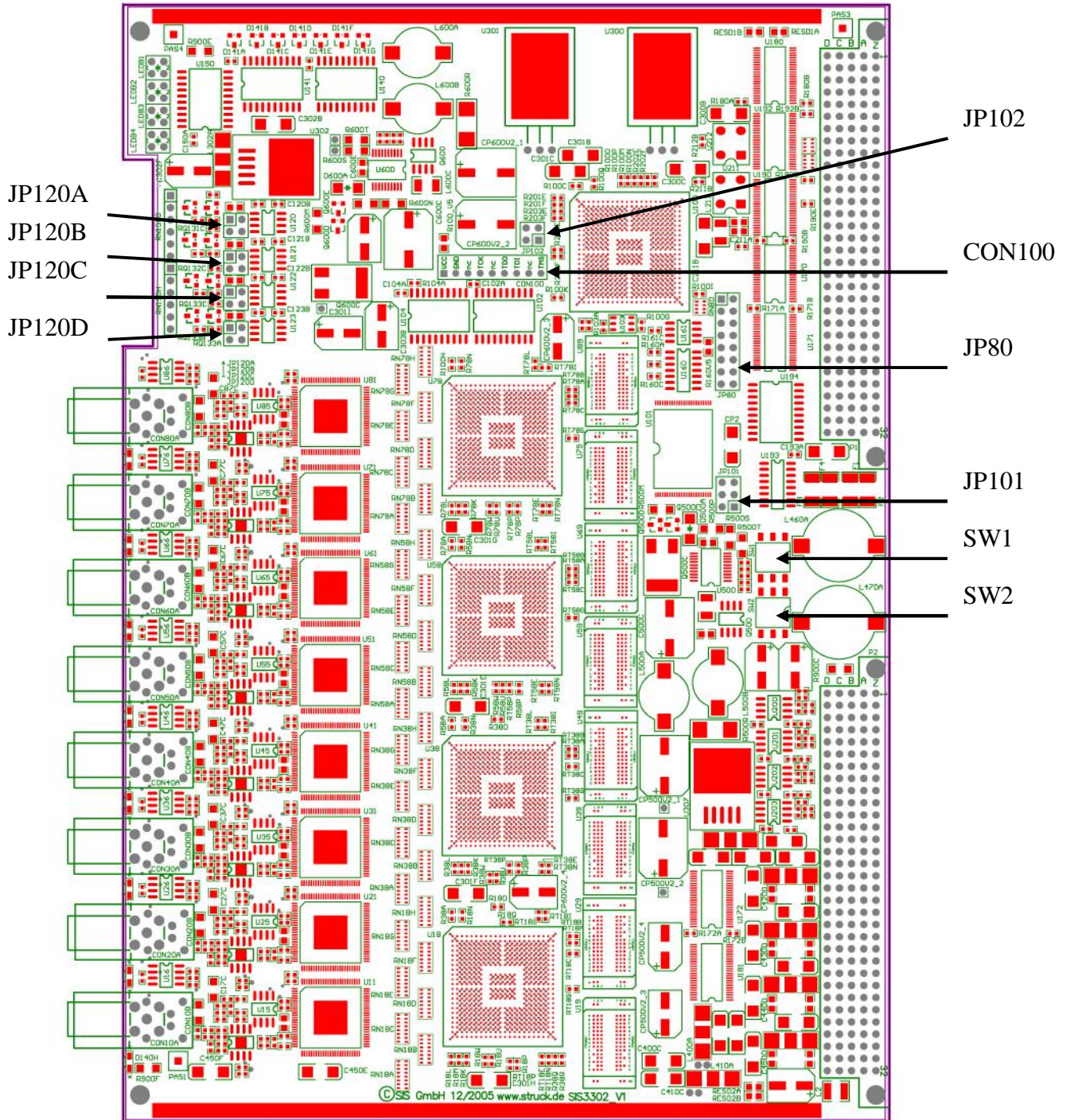

7 Front panel

The SIS3302 is a single width (4TE) 6U VME module. A sketch of the SIS3302 front panel (single ended LEMO00 version without handles) is shown below. The IN/OUT breakouts hold 4 LEMO connectors each.

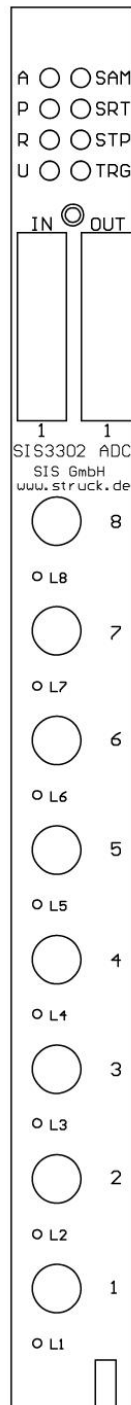

7.1 Control In/Outputs

The control I/O section features 8 LEMO00 connectors with NIM levels.

The assignment of the functions of the LEMO Inputs 1-3 and of the LEMO Outputs 1-3 depends on the programmed LEMO IN Mode and LEMO OUT Mode.

Example for LEMO IN Mode = 0 and LEMO OUT Mode = 0:

Designation	Inputs	Outputs	Designation
4	Clock In	Clock Out	4
3	Trigger In	ADC sample logic armed	3
2	Timestamp Clear	ADC event sampling busy	2
1	Veto	Trigger out	1

The external clock must be a symmetric .

The width of Trigger In /Timestamp Clear pulse must be greater or equal two sampling clock periods.

7.2 LED's

The SIS3302 has 8 front panel LEDs to visualise part of the modules status. The user (and access) LED are a good way to check first time communication/addressing with the module.

Color	Designator	Function
Red	A	Access to SIS3302 VME slave port
Yellow	P	Power
Green	R	Ready, on board logic configured
Green	U	User, to be set/cleared under program control
Red	SAM	Sampling busy on Bank 1
Yellow	SRT	Sampling busy on Bank 2
Green	STP	Lit if the lower Timestamp counter bits 27 to 0 are equal 0x0FFFFFFF (or of all four timestamp counters) . (100MHz -> lit every 2.6 sec)
Green	TRG	Trigger, lit if one or more channels are triggered

The on duration of the access, sampling, start, stop and trigger LEDs is stretched to guarantee visibility even under low rate conditions.

7.3 Channel LED's

The 8 card edge surface mounted LEDs L1, ..., L8 can be seen through the corresponding holes in the front panel. They visualize the trigger status of the corresponding channel. The on duration is stretched for better visibility of short pulses.

7.4 PCB LEDs

The 8 surface mounted red LEDs D141A to D141G on the top left corner of the component side of the SIS3302 are routed to the control FPGA, their use may depend on the firmware design.

8 Jumpers/Configuration

8.1 CON100 JTAG

The SIS3302 on board logic can load its firmware from a serial PROMs , via the JTAG port on connector CON100 or over VME. A list of firmware designs can be found under <http://www.struck.de/sis3302firm.htm>.

Hardware like the XILINX HW-JTAG-PC in connection with the appropriate software will be required for in field JTAG firmware upgrades. The JTAG chain configuration is selected with jumper JP101,jumper JP102 is used to chose VME or CON100 as JTAG source.

The JTAG connector is a 9 pin single row 1/10 inch header, the pin assignment on the connector can be found in the table below.

Pin	Short hand	Description
1	VCC	Supply voltage
2	GND	Ground
3	nc	not connected, cut to avoid polarity mismatch
4	TCK	test clock
5	nc	not connected
6	TDO	test data out
7	TDI	test data in
8	nc	not connected
9	TMS	test modus

8.2 JP80 VME addressing mode/reset behaviour

This 8 position jumper array is used to select the addressing mode and the reset behaviour of the SIS3302.

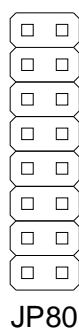

Pos	Function	Factory default
1	A32	closed
2	A16 (not supported)	open
3	GEO (not supported)	open
4	VIPA (not supported)	open
5	connect VME SYSRESET IN to FPGA reset	closed
6	connect watchdog to VME SYSRESET OUT	open
7	connect FPGA reset VME SYSRESET OUT	open
8	connect VME SYSRESET to board reset	closed

The enable watchdog jumper has to be removed during (initial) JTAG firmware load.

NOTE: avoid a power up deadlock situation by not setting Pos. 5 and 7 at the same time

8.3 JP101 JTAG chain

The JTAG chain on the SIS3302 can be configured to comprise the serial PROM only (short JTAG chain) or to comprise the serial PROM and the 5 Spartan III FPGAs (long chain). The configuration is selected with the 6-pin array JP101 as sketched below:

Long Chain (1-3 and 2-4 closed):

JP101

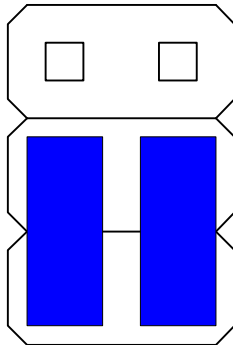

Short Chain (3-5 and 4-6 closed, factory default):

JP101

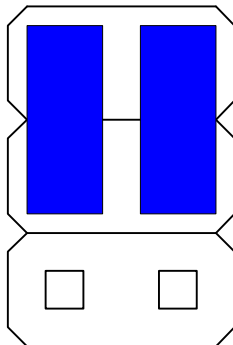

8.4 JP102 JTAG source

The JTAG chain can be connected to VME or to the JTAG connector CON...via the 4 pin jumper array JP102 as sketched below:

JTAG connected to VME (1-2 closed)

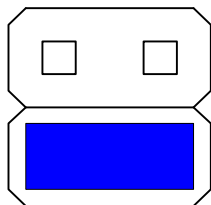

JP102

JTAG connected to connector CON100 (3-4 closed, factory default)

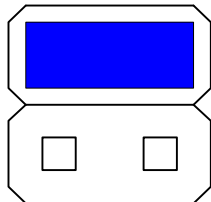

JP102

8.5 JP120A-JP120D control input termination

The contact pair 1-2 of these 4 jumper arrays is used to connect the termination resistor to the 4 control inputs as illustrated with the schematic for JP120A below.

Jumper	Control Input	Factory Default
JP120A	Clock In	Closed
JP120B	Start In	Closed
JP120C	Stop In	Closed
JP120D	User In	Closed

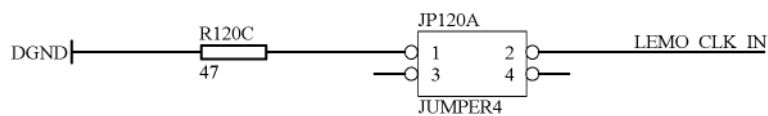

8.6 SW1 and SW2, VME base address

These 2 rotary switches are used to define 2 nibbles of the VME base address in non geographical addressing (refer to section base address also).

Switch	Function
SW1	ADR_UP
SW2	ADR_LO

9 Software/getting started

The original Gamma implementation was developed for a setup consisting of several SIS3150 CMC carrier boards with SIS9300 digitizer CMCs, a SIS3820 clock distributor and a SIS PCI or USB to VME interface. It was adopted for SIS3302 boards in combination with a SIS1100/3100 PCI to VME or SIS3150 USB to VME interface later on. The graphical user interface (GUI) is based on National Instruments CVI. As CVI applications are based on underlying C code you can use the code as basis or examples for adaptations to your environment and application.

The required files are kept in three directories as shown below.

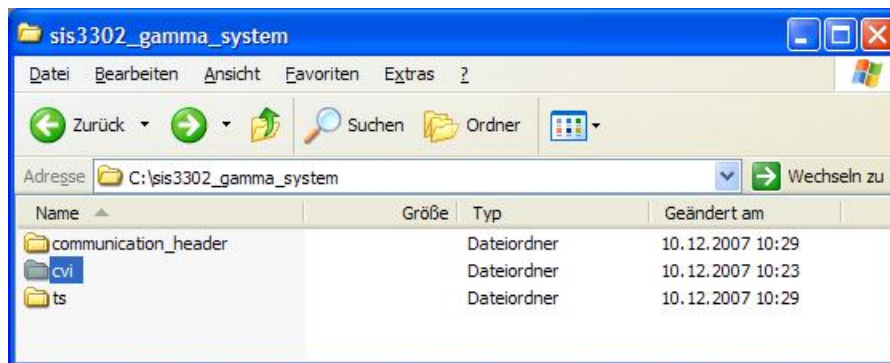

9.1 Header files

The registers of the SIS3302 gamma firmware can be found in:
`sis3302_v1201.h`

If you want to use the routines unchanged you may have to include header files for the SIS3820 clock distributor, for the sis3150 card and for the SIS9300 ADC board.

An overview of all header files of the project can be seen in the screen dump below.

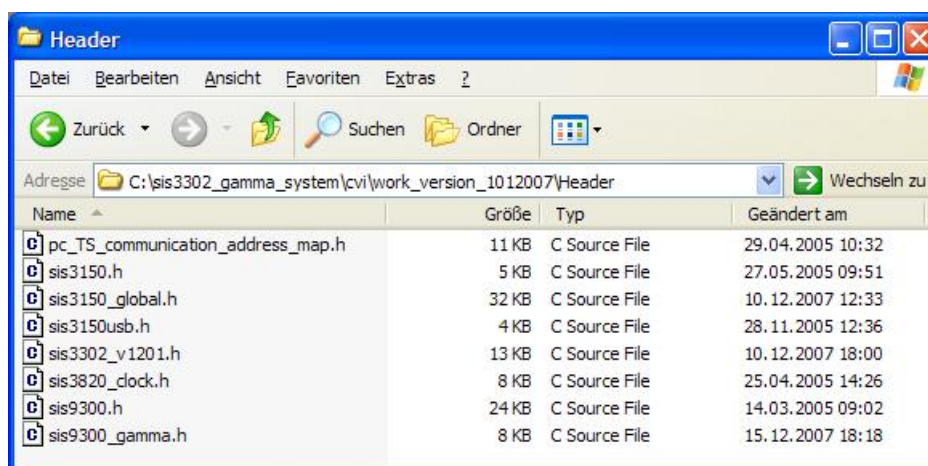

9.2 C code

Following C files are part of the software:

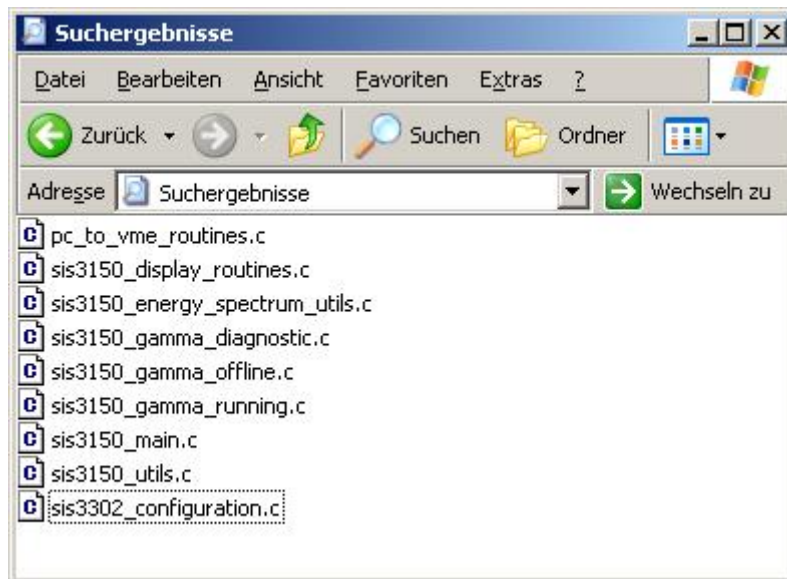

Following files are most important to get started with your own project:
sis3302_configuration.c holds the configuration for the digitizer.
sis3150_gamma_running.c holds the readout code

10 Appendix

10.1 Power consumption

The SIS3302 uses standard VME voltages only.

Voltage	Current
+ 5V	8A
+12 V	115 mA
- 12 V	340 mA

10.2 Operating conditions

10.2.1 Cooling

Although the SIS3302 is mainly a 2.5 and 3.3 V design, substantial power is consumed by the Analog to Digital converter chips and linear regulators however. Hence forced air flow is required for the operation of the board. An air capacity in excess of 160 m³/h is required. Unoccupied adjacent slots of the VME crate have to be equipped with filler modules to ensure proper air flow. The board may be operated in a non condensing environment at an ambient temperature between 10° and 25° Celsius. A power up warm up time of some 10 minutes is recommended to ensure equilibrium on board temperature conditions.

10.2.2 Hot swap/live insertion

Please note, that the VME standard does not support hot swap by default. The SIS3302 is configured for hot swap in conjunction with a VME64x backplane. In non VME64x backplane environments the crate has to be powered down for module insertion and removal.

10.3 Connector types

The VME connectors and the different types of front panel connectors used on the SIS3302 are:

Connector	Purpose	Part Number
160 pin zabcd	VME P1/P2	Harting 02 01 160 2101
LEMO PCB	Coax. control connector	LEMO EPB.00.250.NTN
90° PCB LEMO	Analog input connector	LEMO EPL.00.250.NTN
90° PCB	Analog input connector (SMA option)	SMA
90° PCB LEMO	Analog input connector (3302 differential input version)	LEMO EPL.0S.302.HLN

10.4 P2 row A/C pin assignments

The P2 connector of the SIS3302 has several connections on rows A and C for the F1002 compatible use at the DESY H1 FNC subdetector. This implies, that the module can not be operated in a VME slot with a special A/C backplane, like VSB e.g.. The pin assignments of P2 rows A/C of the SIS3302 is shown below:

P2A	Function	P2C	Function
1	-5.2 V	1	-5.2 V
2	-5.2 V	2	-5.2 V
3	-5.2 V	3	-5.2 V
4	not connected	4	not connected
5	not connected	5	not connected
6	DGND	6	DGND
7	P2_CLOCK_H	7	P2_CLOCK_L
8	DGND	8	DGND
9	P2_START_H	9	P2_START_L
10	P2_STOP_H	10	P2_STOP_L
11	P2_TEST_H	11	P2_TEST_L
12	DGND	12	DGND
13	DGND	13	DGND
14	DGND	14	DGND
15	DGND	15	DGND
16	not connected	16	not connected
...	...	17	...
31	not connected	18	not connected

Note: The P2 ECL signals are bussed and terminated on the backplane of F1002 crates. The user has to insure proper termination if a cable backplane or add on backplane is used.

10.5 Row d and z Pin Assignments

The SIS3302 is prepared for the use with VME64x and VME64xP backplanes. Foreseen features include geographical addressing (PCB revisions V2 and higher) and live insertion (hot swap). The prepared pins on the d and z rows of the P1 and P2 connectors are listed below.

Position	P1/J1		P2/J2	
	Row z	Row d	Row z	Row d
1		VPC (1)		
2	GND	GND (1)	GND	
3				
4	GND		GND	
5				
6	GND		GND	
7				
8	GND		GND	
9		GAP*		
10	GND	GA0*	GND	
11	RESP*	GA1*		
12	GND		GND	
13		GA2*		
14	GND		GND	
15		GA3*		
16	GND		GND	
17		GA4*		
18	GND		GND	
19				
20	GND		GND	
21				
22	GND		GND	
23				
24	GND		GND	
25				
26	GND		GND	
27				
28	GND		GND	
29				
30	GND		GND	
31		GND (1)		GND (1)
32	GND	VPC (1)	GND	VPC (1)

Note: Pins designated with (1) are so called MFBL (mate first-break last) pins on the installed 160 pin connectors, VPC(1) pins are connected via inductors.

10.6 Firmware upgrade

The firmware of the SIS3302 can be upgraded over JTAG. The upgrade options are VME (on units that have intact firmware) and the JTAG connector CON100. The VME upgrade option is not tested for the current 01 02 firmware release yet.

10.6.1 Upgrade over CON100

The firmware can be upgraded with the Xilinx Impact software, which is part of the Webpack that can be downloaded from the Xilinx web page for free. A version of the Webpack software (which may not be up to date and not compatible with your JTAG hardware) can be found in the xilinx_webpack directory of the Struck Innovative Systeme CDROM also. A Xilinx JTAG parallel cable or USB (Xilinx part number HW-USB) cable can be used to roll in the firmware.

Configure the SIS3302 for short JTAG chain (refer to section 8.3 JP101) and set the unit to JTAG over CON100 (refer to section 8.4 JP102 JTAG source).

With your hard- and software properly set up you should see a screen as illustrated below after executing the initialize chain command.

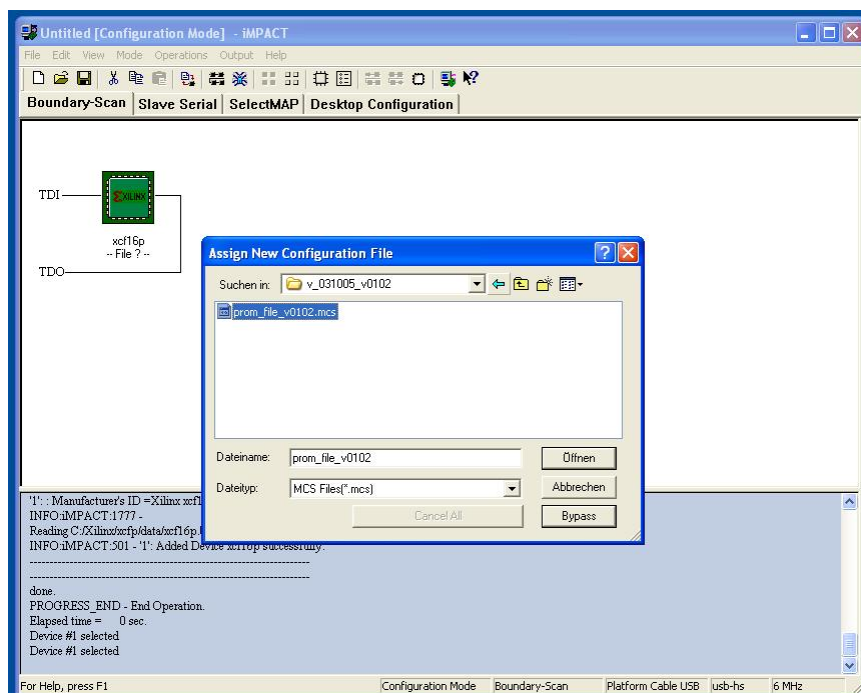

Load the mcs file to the serial PROM (shown as xcf16p).

10.6.2 Upgrade over VME

not tested with SIS3302 firmware 12 02 yet

11 Index

00.....	92	gate	
0S.....	92	external.....	52
0x140x.....	29	internal.....	52
4TE.....	82	geographical addressing.....	93
6U.....	82	getting started.....	89
A32.....	28	GND.....	85
AD5570.....	43	H1.....	92
Address Map.....	29	Harting.....	92
address space.....	28	header files.....	89
air capacity.....	91	hot swap.....	91, 93
arm	49	HPGe.....	7
backplane.....	91	HW-USB.....	94
board layout.....	81	input	
broadcast		clock.....	83, 88
address.....	41	control.....	83
enable.....	40	start.....	83, 88
master.....	40	stop.....	83, 88
C code.....	90	user in.....	83, 88
CBLT.....	40	internal 100MHz.....	37
clock		interrupter mode.....	34
doubling.....	37	interrupter type.....	34
external.....	37	introduction.....	7
external.....	37	invert.....	52
clock source.....	36, 37	IRQ	
CMC.....	89	bank full.....	35
CON100.....	85, 94	end of event.....	35
configuration.....	85	user input.....	35
connector types.....	92	IRQ mode.....	34
control		ROAK.....	34
output.....	83	RORA.....	34
control input.....	83	J/K.....	36
control register.....	32	J1P20B.....	88
cooling.....	91	JP101.....	85, 86, 87
CVI.....	32	JP102.....	85
CVI plots.....	25	JP120A.....	88
D141A.....	84	JP120C.....	88
DAC.....	43	JP120D.....	88
DAC load sequence.....	44	JP80.....	28, 85
deadtime.....	22	JTAG.....	85, 94
table.....	22	JTAG chain.....	86
deconvolution.....	14	JTAG source.....	87
DESY.....	92	jumper	
disarm and arm bank 1.....	50	reset.....	85
DO8.....	34	KA	
double buffer acquisition.....	80	<i>disarm sample logic</i>	49
Energy filter.....	27	general reset.....	49
FAST FIR Filter.....	10	<i>MCA Multiscan Arm with Scan operation Arm</i>	
FIR.....	7, 10	51
firmware.....	85	<i>MCA Multiscan Arm with Scan operation</i>	
firmware upgrade.....	94	<i>Enable</i>	51
FNC.....	92	<i>MCA Multiscan Disable</i>	51
FPGA		<i>MCA Multiscan Start/Reset pulse</i>	51
control.....	84	<i>MCA Scan Disable</i>	51
front panel.....	82	<i>MCA Scan Enable</i>	51
G 49		<i>MCA Scan LNE pulse</i>	50
GA.....	28	<i>MCA Scan Operation Arm</i>	50
gamma logic implementation.....	9	sample logic reset.....	49

<i>timestamp clear</i>	49	parameter illustration.....	15
<i>VME trigger</i>	49	parameters	16
KEY		PCB.....	93
disarm and arm bank 1	50, 80	power consumption	91
disarm and arm bank 2	50, 80	PROM	85, 94
general reset.....	49	raw pre sample length	56
key address.....	41	raw sample length	56
L1.....	84	raw signal	26
Labwindows	45	register	
LED		acquisition control.....	36
A 84		actual sample	58
access	84	actual sample value	45
P 84		ADC memory page.....	42, 77
R 84		broadcast setup.....	40, 41
SAM.....	84	control	33
SRT	84	DAC control.....	43
STP	84	dac data.....	44
TRG	84	DAC status.....	43
U 84		description	32
user.....	32, 84	end address threshold	54
LEDs		energy gate length	68
channel.....	84	energy sample	68
front panel	84	energy sample length.....	69
LEMO	92	energy sample start index 1.....	69
LEMO IN Mode	39	energy sample start index 2.....	69
LEMO IN Mode	36	energy sample start index 3.....	69
LEMO OUT Mode	37	energy setup GP	67
LEMO OUT Mode	36	energy tau factor.....	70
live insertion.....	91, 93	event configuration.....	52
M 59, 60, 67		event extended configuration.....	53
MA.....	14, 25	firmware revision	33
MAW	26	interrupt configuration.....	34
MAWD	13, 27	interrupt control	35
MCA ENERGY_to_Histogram Calculation		MCA ENERGY_to_High counter.....	76
Parameter.....	72	MCA ENERGY_to_Low counter	76
MCA Histogram Parameter.....	74	MCA histogram counter	46
MCA Mode	36	MCA LNE Setup and Prescaler Factor.....	46
MCA Mode	23	MCA Multiscan Last Scan Histogram counter	48
MCA Multiscan Arm Scan Arm.....	24	MCA Multiscan Nof Scans preset.....	48
MCA Multiscan Arm Scan Enable	24	MCA Multiscan Scan counter.....	48
MCA Scan Arm.....	23	MCA Pileup counter.....	75
MCA Scan Enable	23	MCA Scan Control.....	47
memory	31, 77	MCA Scan nof histograms preset.....	46
modes of acquisition	80	MCA Trigger Start counter.....	75
moving average	14, 25	module Id.....	33
Next Neighbor gate enable.....	52	next sample address.....	57
Next Neighbor trigger enable	53	pretrigger delay and trigger gate length.....	55
Next Neighbor Trigger/Gate logic.....	19	previous bank sample address.....	57
operating conditions.....	91	raw data buffer config all ADC.....	56
output		trigger extended setup.....	60
bank full	83	trigger setup	59
clock.....	83	trigger threshold.....	62, 66
trigger.....	83	reset.....	49, 85
user.....	83	ROAK	34
P 49, 59, 60, 67		RORA	34
P1.....	93	sample logic.....	21
P2.....	93	Second internal 100MHz.....	37
pin assignments.....	92	single event acquisition	80
termination	92	SIS1100/3100	89
Page Clear Time table.....	23	SIS3150.....	89

sis3150_3302_gamma.....	32	trigger	
sis3302_v1201.h.....	32	disabled.....	62
SIS3320.....	89	external.....	52
SIS9300.....	89	internal.....	52
SMA.....	92	trigger example	64
Software.....	89	trigger generation.....	10
status register.....	32	Trigger MAW.....	11
SW1.....	28, 88	Trigger/Gate logic.....	17
SW2.....	28, 88	user	
Tau correction.....	26, 27	LED.....	32
TCK.....	85	VCC.....	85
TDI.....	85	VME.....	91
TDO.....	85	connector.....	92
termination		VME addressing.....	28
P2.....	92	VME64x.....	91, 93
TMS.....	85	VME64xP.....	93
trapezoidal energy filter.....	12	VSB.....	92
trapezoidal trigger filter.....	10		