

# Precision High Voltage Supply VME STANDARD series

## Operators Manual

### Contents:

1. General information

2. Technical Data

3. VHQ Description

4. Front panel

5. Handling

6. VME Interface

7. Program example

Appendix A: Block diagram

Appendix B: Rotary switch locations

### Attention!

-It is not allowed to use the unit if the covers have been removed.

-We decline all responsibility for damages and injuries caused by an improper use of the module. It is highly recommended to read the operators manual before any kind of operation.

### Note

The information in this manual is subject to change without notice. We take no responsibility whatsoever for any error in the document. We reserve the right to make changes in the product design without reservation and without notification to the users.

Filename VHQ20x\_01\_eng; version 3.01 as of 2005-10-12





## 1. General information

The VHQ's are two channel high voltage supplies in 6U VME format, 164 mm deep, double width. The units offers manual control and operation via VME bus. The use of the VME interface supports more then the manual control functionality.

The high voltage supplies special provide high precision output voltage together with very low ripple and noise, even under full load. Separate 10%-steps hardware switches put voltage and current limits. An INHIBIT input protects connected sensitive devices. Additionally, the maximal output current per channel is programmable via the interface. The high voltage outputs protected against overload and short circuit. The output polarity can be switched over. The HV-GND is connected to the chassis and the powering GND.

## 2. Technical data:

VHQ two channel	202 M	203 M	204 L	205 L
Output voltage $V_O$	0 ... 2 kV	0 ... 3 kV	0 ... 4 kV	0 ... 5 kV
Output current per channel $I_O$	0 ... 3 mA	0 ... 2 mA	0 ... 1 mA	0 ... 1 mA
with <b>option M - h</b>	0 ... 6 mA	0 ... 4 mA	0 ... 3 mA	0 ... 2 mA
with <b>option _104</b>	100 $\mu$ A	100 $\mu$ A	100 $\mu$ A	100 $\mu$ A
Ripple	typ. < 0,5 mV <sub>P-P</sub>	< 0,5 mV <sub>P-P</sub>	< 1 mV <sub>P-P</sub>	< 2 mV <sub>P-P</sub>
max.	2 mV <sub>P-P</sub>	2 mV <sub>P-P</sub>	2 mV <sub>P-P</sub>	5 mV <sub>P-P</sub>
with <b>option M - h</b> typ.	< 2 mV <sub>P-P</sub>	< 2 mV <sub>P-P</sub>	< 3 mV <sub>P-P</sub>	< 4 mV <sub>P-P</sub>
with <b>option M - h</b> max.	5 mV <sub>P-P</sub>	5 mV <sub>P-P</sub>	5 mV <sub>P-P</sub>	8 mV <sub>P-P</sub>
Stability	$\frac{\Delta V_O}{\Delta V_{INPUT}}$			
$\frac{\Delta V_O}{\Delta V_{INPUT}}$	< 5 * 10 <sup>-5</sup> (idle to max. load)			
$\frac{\Delta V_O}{\Delta V_{INPUT}}$	< 5 * 10 <sup>-5</sup>			
Temperature coefficient	< 5 * 10 <sup>-5</sup> /K			
LCD Display	4 digits with sign, switch controlled voltage display in [V] / current display in [ $\mu$ A]			
Resolution of measurement	Current: 1 $\mu$ A, with <b>option _104</b> : 100 nA Voltage: 1 V			
Accuracy current measurement	$\pm(0,05\% I_O + 0,02\% I_{O_{max}} + 1 \text{ digit})$ (for one year)			
Accuracy voltage measurement	$\pm(0,05\% V_O + 0,02\% V_{O_{max}} + 1 \text{ digit})$ (for one year)			
Voltage control	CONTROL switch in upper position: 10 - turn potentiometer lower position (DAC): control via interface			
Rate of change of output voltage	hardware ramp 500 V/s (on HV-ON/ -OFF) software ramp: 2 . . . 255 V/s			
Protection	- separate current and voltage limit (hardware, rotary switch in 10%-steps) - INHIBIT (ext. signal TTL-level, Low = active $\Rightarrow V_{OUT}=0$ ) - programmable current limit (software): Current trip reaction time < 60 ms			
Power requirements $V_{INPUT}$	$\pm 12 \text{ V}$ (< 850 mA, with <b>option M - h</b> < 1,6 A) + 5 V (< 300 mA)			
Packing	VME #2 / 6U / 164 mm deep			
Connector	96-pin VME connector according to DIN 41612			
HV connector	SHV-Connector at the front panel			
INHIBIT connector	1-pin Lemo-hub			
Operating temperature	0 ... +50 °C			
Storage temperature	-20 ... +60 °C			

### 3. VHQ Description

The function is described at a block diagram of the VHQ. This can be found in Appendix A.

#### High voltage supply

A patented high efficiency resonance converter circuit, which provides a low harmonic sine voltage on the HV-transformer, is used to generate the high voltage. The high voltage is rectified using a high speed HV-rectifier, and the polarity is selected via a high-voltage switch. A consecutive active HV-filter damps the residual ripple and ensures low ripple and noise values as well as the stability of the output voltage. A precision voltage divider is integrated into the HV-filter to provide the set value of the output voltage, an additional voltage divider supplies the measuring signal for the maximum voltage control. A precision measuring and AGC amplifier compares the actual output voltage with the set value given by the DAC (computer control) or the potentiometer (manual control). Signals for the control of the resonance converter and the stabilizer circuit are derived from the result of the comparison. The two-stage layout of the control circuit results in an output voltage, stabilized with very high precision to the set point.

Separate security circuits prevent exceeding the front-panel switch settings for the current  $I_{\max}$  and voltage  $V_{\max}$  limits. A monitoring circuit prevents malfunction caused by low supply voltage.

The internal error detection logic evaluates the corresponding error signals and the external INHIBIT signal. It allows the detection of short overcurrent due to single flashovers in addition.

#### Digital control unit

A micro controller handles the internal control, evaluation and calibration functions of both channels. The actual voltages and currents are read cyclically by an ADC with connected multiplexer and processed for display on the 4 digit LCD display. The current and voltage hardware limits are retrieved cyclically several times per second. The reference voltage source provides a precise voltage reference for the ADC and generation of the control signals in the manual operation mode of the unit.

The set values for the corresponding channels are generated by a 16-Bit DAC in computer controlled mode.

#### Filter

A special property of the unit is a tuned filtering concept, which prevents radiation of electromagnetic interference into the unit, as well as the emittance of interference by the module. A filtering network is located next to the connectors for the supply voltage and the converter circuits of the individual devices are also protected by filters. The high-voltage filters are housed in individual metal enclosures to shield even minimum interference radiation.

## 4. Front panel

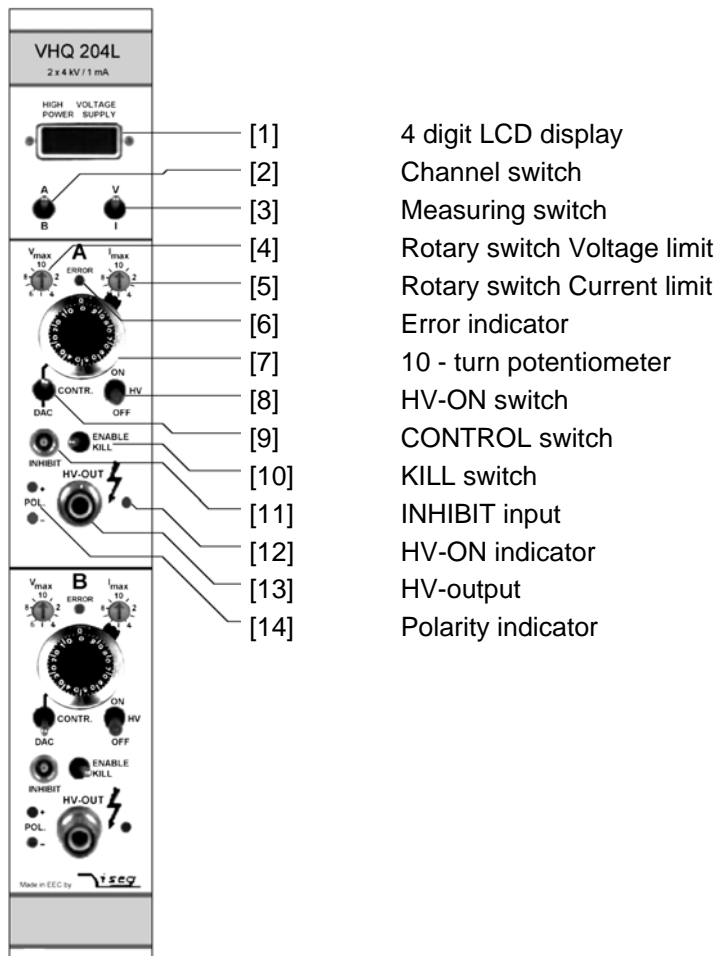

## 5. Handling

The state of readiness of the unit is produced at the VME connector on the flipside.

The Output polarity is selectable with help of a rotary switch on the cover side (see appendix B). The chosen polarity is displayed by a LED on the front panel [14] and a sign on the LCD display [1].

**Attention!** It is not allowed to change the polarity under power!

An undefined switch setting (not at one of the end positions) will cause no output voltage.

High voltage output is switched on with HV-ON switch [8] at the front panel. The viability is signaled by the yellow LED [12].

**Attention!** If the CONTROL switch [9] is in upper position (manual control), high voltage is generated at HV-output [13] on the front panel with a ramp speed from 500 V/s (hardware ramp) to the set voltage chosen via 10-turn potentiometer [7].  
This is also the case, if VME control is switched over to manual control while operating.

If the CONTROL switch [9] is in lower position (DAC), high voltage will be activated only after receiving corresponding VME commands.

On the LCD [1] output voltage in [V] or output current in [ $\mu$ A] will be displayed depending on the position of the Measuring switch [3].

For the two channel units, one can choose with Channel switch [2], if channel (A) or channel (B) is displayed.

If working with manual control, output voltage can be set via 10-turn potentiometer [7] in a range from 0 to the set maximal voltage.

If the CONTROL switch [9] is switched over to VME control, the DAC takes over the last set output voltage of manual control. Output voltage can be generated with a programmable ramp speed (software ramp) from 2 to 255 V/s in a range from 0 to the maximal set voltage via VME control.

The maximum output current per channel can be set with a programmable current trip via the interface with the resolution of current measurement. If the output current exceeds the programmable limit, the output voltage will be shut off permanently by the software. Restoring the voltage is possible after reading " Status register 2" and then "Start voltage change" via interface.

Maximum output voltage and current can be selected in 10%-steps with the rotary switches  $V_{max}$  [4] and  $I_{max}$  [5] (switch dialed to 10 corresponds to 100%) independently of programmable current trip. The output voltage or current, which exceed the limits, is signaled by the red error LED on the front panel [6].

Function of KILL switch [10]:

Switch to the right position: (ENABLE KILL) The output voltage will be shut off permanently without ramp on exceeding  $V_{max}$ ,  $I_{max}$  or in the presence of an INHIBIT signal (Low=active) at the INHIBIT input [11]. Restoring the output voltage is possible after operating the switches HV-ON or KILL or reading " Status register 2" and then "Start voltage change" by DAC control.

Note: When capacitance is effective at the HV-output or when the rate of change of output voltage is high (hardware ramp) at high load, then the KILL function will be released by the current charging the condenser. In this case use a small rate of output change (software ramp) or select ENABLE KILL not until output voltage is set voltage.

Switch to the left position: (DISABLE KILL) The output voltage will be limited to  $V_{max}$ , output current to  $I_{max}$  respectively; INHIBIT shuts the output voltage off without ramp, the previous voltage setting will be restored with hard- or software ramp on INHIBIT no longer being present.

## 6. VME Interface

Modus: short supervisory access (AM = 0x2D)  
short nonprivileged access (AM = 0x29)

### Control via VME interface

1<sup>st</sup> write: set voltage, ramp speed, maximal output current (current trip)  
2<sup>nd</sup> switch: output voltage = set voltage ; output voltage = 0  
3<sup>rd</sup> read: set voltage; actual voltage; ramp speed; actual current; current trip  
current and voltage hardware limit; status

Front panel switches are having priority over software control.

### Manual control

While the unit is operated in manual control mode, VME read cycles are interpreted only. Commands are accepted, but do not result in a change of the output voltage.

## Command Execution Time

The command execution time is 2  $\mu$ s typical.

## Base Address

The base address BA is saved in a EEPROM. Setting BA:

1. Set both channels of the unit before power requirements ( $\pm 12V$ ; + 5V) are activated as follows:  
=> CONTROL switch at MANUELL; => HV-ON switch at OFF; => KILL switch at ENABLE.
2. Activate power requirements.
3. LCD display shows "A" on the left side and the highbyte of the base address (e.g. "dd") on the right side, with separator flashing in between.
4. High-order nibble can be set with channel switch and low-order nibble with measuring switch.
5. In case of no change for 10 s or of setting another switch respectively, the chosen base address is saved in EEPROM and the unit is responsive with it.
6. Factory setting: BA = 0xDD00

## Register addresses

The description for Channel B will be cancelled at the one channel unit.

A7	A6	A5	A4	A3	A2	A1	Read	Write
0	0	0	0	0	0	0	Status register 1	
0	0	0	0	0	1	0	Set voltage Channel A [V]	Set voltage Channel A ( $V_{set} \leq V_{max}$ ) [V]
0	0	0	0	1	0	0	Set voltage Channel B [V]	Set voltage Channel B ( $V_{set} \leq V_{max}$ ) [V]
0	0	0	0	1	1	0	Ramp speed Channel A (2... 255) [V/s]	Ramp speed Channel A (2... 255) [V/s]
0	0	0	1	0	0	0	Ramp speed Channel B (2... 255) [V/s]	Ramp speed Channel B (2... 255) [V/s]
0	0	0	1	0	1	0	Actual voltage Channel A [V]	
0	0	0	1	1	0	0	Actual voltage Channel B [V]	
0	0	0	1	1	1	0	Actual current Channel A )	
0	0	1	0	0	0	0	Actual current Channel B )	
0	0	1	0	0	1	0	Hardware limits Channel A ( $I_{max}$ , $V_{max}$ )	
0	0	1	0	1	0	0	Hardware limits Channel B ( $I_{max}$ , $V_{max}$ )	
0	0	1	0	1	1	0	Data ready	
0	0	1	1	0	0	0	Status register 2	
0	0	1	1	0	1	0	Start voltage change Channel A	Start voltage change Channel A with data: Set voltage Channel A [V]
0	0	1	1	1	0	0	Start voltage change Channel B	Start voltage change Channel B with data: Set voltage Channel B [V]
0	0	1	1	1	1	0	Module identifier	
0	1	0	0	0	0	0	-	-
0	1	0	0	0	1	0	Current software limit Channel A	Current software limit Channel A
0	1	0	0	1	0	0	Current software limit Channel B	Current software limit Channel B

) corresponding current resolution

with data: maximal current Channel A/B  
corresponding current resolution,  
maximal current = 0  $\Rightarrow$  not a current trip

**Status register 1 (BA + 0x00)**

Channel	Bit	Name	Description	0	1
<b>B</b>	D15	ERROR_2	Error on Channel B	Channel ok	Error
	D14	STATV_2	Status $V_{out}$	$V_{out}$ stable	$V_{out}$ in change
	D13	TRENDV_2	Ramp up / down	$V_{out}$ falling	$V_{out}$ rising
	D12	KILL_2	KILL switch setting	Disabled	Enabled
	D11	ON_OFF_2	HV-ON/OFF switch setting	On	Off
	D10	POL_2	Polarity $V_{out}$	Negative	Positive
	D9	IN_EX_2	CONTROL switch setting	DAC	Manual
	D8	VZ_2	$V_{out} = 0$	$V_{out} <> 0$	$V_{out} = 0$
<b>A</b>	D7	ERROR_1	Error on Channel A	Channel ok	Error
	D6	STATV_1	Status $V_{out}$	$V_{out}$ stable	$V_{out}$ in change
	D5	TRENDV_1	Ramp up / down	$V_{out}$ falling	$V_{out}$ rising
	D4	KILL_1	KILL switch setting	Disabled	Enabled
	D3	ON_OFF_1	HV-ON/OFF switch setting	On	Off
	D2	POL_1	Polarity $V_{out}$	Negative	Positive
	D1	IN_EX_1	CONTROL switch setting	DAC	Manual
	D0	VZ_1	$V_{out} = 0$	$V_{out} <> 0$	$V_{out} = 0$

This register is representing the general status of the VHQ.

“Error“ is formed by the logic or of REG2ER\_, REG1ER\_, EXTINH\_, RANGE\_ and ILIM\_ from “Status register 2”.

“ $V_{out}=0$ “ is formed by DAC output = 0 and actual voltage < 5 V.

**Set voltage Channel A/B (BA + 0x04 / BA + 0x08)**

Set voltage  $V_{set}$  from 0 to  $V_{max}$  in V. If  $V_{set}$  greater then  $V_{max}$  (BA + 0x24 / BA + 0x28),  $V_{set}$  will be not changed.

**Ramp speed Channel A/B (BA + 0x0C / BA + 0x10)**

Voltage ramp speed from 2 V/s to 255 V/s. All processor controlled changes in the output voltage are performed at this ramp speed.

**Actual voltage Channel A/B (BA + 0x14 / BA + 0x18)**

Output voltage  $V_{out}$  of the channels in V.

**Actual current Channel A/B (BA + 0x1C / BA + 0x20)**

Output current  $I_{out}$  of the channels corresponding current resolution.

**Hardware limits (BA + 0x24 / BA + 0x28)**

- D0 .. D3 Maximal output current ( $I_{max}$ ) in 10 %, hardware setting on the front panel switches
- D4 .. D7 Maximal output voltage ( $V_{max}$ ) in 10 %, hardware setting on the front panel switches
- D8 .. D15 0

**Data ready (BA + 0x2C)**

D7	D6	D5	D4	D3	D2	D1	D0
0	0	0	0	Current B	Voltage B	Current A	Voltage A

The individual bits are set as soon as actual measured data is existing. The bits are reset after the corresponding reading command.



Status register 2 (BA + 0x30)

	Bit	Name	Description	Remark
<b>Channel B</b>	D15	REG2ER_2	Quality of output voltage not given at present	
	D14	REG1ER_2	$V_{max}$ or $I_{max}$ is / was exceeded	
	D13	EXTINH_2	External inhibit was / is active	
	D12	RANGE_2	$V_{set}$ to $V_{max}$ ratio > 1	$D(BA+0x08) > V_{max}$
	D11	KEY_CHANGED	A frontpanel switch position was changed	ON_OFF_2, IN_EXT_2, KILL_2
	D10	EOP_2	$V_{out}$ has reached set value	End of process_2
	D9	ILIM_2	$I_{out}$ was > $I_{max}$ programmable	Current trip
	D8			
<b>Channel A</b>	D7	REG2ER_1	Quality of output voltage not given at present	
	D6	REG1ER_1	$V_{max}$ or $I_{max}$ is / was exceeded	
	D5	EXTINH_1	External inhibit was / is active	
	D4	RANGE_1	$V_{set}$ to $V_{max}$ ratio > 1	$A(BA+0x04) > V_{max}$
	D3	KEY_CHANGED	A frontpanel switch position was changed	ON_OFF_1, IN_EXT_1, KILL_1
	D2	EOP_1	$V_{out}$ has reached set value	End of process_1
	D1	ILIM_1	$I_{out}$ was > $I_{max}$ programmable	Current trip
	D0	TOT	Timeout error	New initialisation

The individual bits are set on the occurrence of the event. A general clear is performed after readout.

If the Output voltage was permanently switched off by exceeding  $V_{max}$  or  $I_{max}$  (ENABLE KILL resp. Current trip), or INHIBIT respectively, the error bits (REG1ER\_, EXTINH\_, ILIM\_) have to be reset by reading " Status register 2" before an output voltage can be set again.

Start voltage change (BA + 0x34 / Ba + 0x38)

A change in the output voltage of set voltage (BA + 0x04 / BA + 0x08) is performed by reading these registers. Writing to the registers stores the data as new set voltage ( $V_{set} \leq V_{max}$ ) and starts the voltage change.

The change of output voltage is blocked, if the conditions are unavailable to start voltage change corresponding these description.

Command execution can be checked by reading status register 1 (BA + 0x00). The bits D14 (channel B), D6 (channel A) respectively are set on start of voltage change. Actual voltage reaching the set voltage is flagged by the bits D10, D2 of status register 2 (BA + 0x30) respectively. An interruption of the voltage change (e.g. external INHIBIT is active) is also ascertainable.

Module identifier (BA + 0x3C)

D15 .. D0 4 digit serial number, BCD coded

Current software limit (BA + 0x44 / BA + 0x48)

The maximal output current per channel corresponding current resolution. If the output current exceeds the programmable limit, the output voltage will be shut off permanently by the software (Current trip). The Current trip reaction time is lessen to 60 ms.

Writing to the registers with maximal output current = 0, not a current trip will be programmed.

Hardware maximum output current limit ( $I_{max}$ ) worked independently of programmable current software limit.

## 7. Program example

```

/*****/
/*      vhf.c                                */
/*      example program for iseg vme hv boards */
/*      mki, 24.1.96                          */
/*      this code was compiled and run on an E6 under OS9 */
/*      please contact iseg for the source files */
/*****/

#include <stdio.h>
#include "vhq.h"
#define base 0xFFFFDD00
int main()
{
    ushort value_s;
    ushort serial;
    ushort imaxa,imaxb,vmaxa,vmaxb;

    value_s = *(ushort*) (base+MOD_ID);          /* read board id */
    serial = (value_s >> 12)* 1000 + ((value_s & 0x0f00) >> 8) * 100
            + ((value_s & 0x00f0) >> 4) * 10 + (value_s & 0x000f);
    printf("This board is serial no.: %d\n",serial);

    value_s = *(ushort*) (base+STAT_REG1);      /* check on DAC/manual switch setting */
    if ((value_s & 0x202) != 0)
    {
        printf("one of the two channels is in manual mode\n");
        printf("program terminating\n");
        return(-1);
    }
    printf("both channels in DAC mode, ok.\n");

    if ((value_s & 0x808) != 0)                  /* check on HV ON/OFF switch setting */
    {
        printf("one of the two channels is OFF\n");
        printf("program terminating\n");
        return(-1);
    }
    printf("both channels ON, ok.\n");

    if ((value_s & 0x4) != 0)                   /* whats the output polarity? */
        printf("polarity of channel A is positive\n");
    else
        printf("polarity of channel A is negative\n");
    if ((value_s & 0x400) != 0)
        printf("polarity of channel B is positive\n");
    else
        printf("polarity of channel B is negative\n");
    sleep(1);

    value_s = *(ushort*) (base+LIMITS_A)       /* read Vmax and Imax */;
    vmaxa=((value_s & 0xf0) >> 4) * 10;
    imaxa=(value_s & 0x0f) * 10;
    printf("Vmax(A): %4d %%, Imax(A): %4d %%\n",vmaxa,imaxa);
    sleep(1);
    value_s = *(ushort*) (base+LIMITS_B);
    vmaxb=((value_s & 0xf0) >> 4) * 10;
    imaxb=(value_s & 0x0f) * 10;
    printf("Vmax(B): %4d %%, Imax(B): %4d %%\n",vmaxb,imaxb);

    *(ushort*) (base+RAMP_SPEED_A) = 100;     /* set ramp speed 100 V/s */
    printf("ramp A set\n");
    *(ushort*) (base+RAMP_SPEED_B) = 100;
    printf("ramp B set\n");

    *(ushort*) (base+SET_CTRIP_A) = 100;      /* set channel A software current trip to 100 µA */
    /*
    printf("channel A current trip set\n");
    *(ushort*) (base+SET_CTRIP_B) = 0;        /* channel B without software current trip */
    printf("channel B current trip set\n");

```

```

*(ushort*) (base+START_VOLT_A) = 400;                               /*set channel A voltage to 400 V */
printf("channel A voltage set\n");

*(ushort*) (base+START_VOLT_B) = 350;                               /*set channel B voltage to 350 V */
printf("channel B voltage set\n");

sleep(5);                                                           /* give the unit time to ramp */

value_s = *(ushort*) (base+ACT_VOLT_A);                             /* read actual voltages */
printf("channel A is at %d V\n",value_s);
sleep(1);                                                           /* allow for a new conversion */
value_s = *(ushort*) (base+ACT_VOLT_B);
printf("channel B is at %d V\n",value_s);

printf("press any key to ramp down and exit\n");                   /* ramp channels down */
getc(stdin);
*(ushort*) (base+START_VOLT_A) = 0;                                 /*set channel A voltage to 0 V */
sleep(1);
*(ushort*) (base+START_VOLT_B) = 0;                                 /*set channel B voltage to 0 V */
return(0);
}

/*****
/*      vhq.h                                     */
/*      header file for iseg vme hv boards      */
/*      mki, 24.1.96                             */
*****/

/* vhq registers */

#define STAT_REG1      0x00
#define SET_VOLT_A    0x04
#define SET_VOLT_B    0x08
#define RAMP_SPEED_A  0x0C
#define RAMP_SPEED_B  0x10
#define ACT_VOLT_A    0x14
#define ACT_VOLT_B    0x18
#define ACT_CUR_A     0x1C
#define ACT_CUR_B     0x20
#define LIMITS_A      0x24
#define LIMITS_B      0x28
#define STAT_REG2     0x30
#define START_VOLT_A  0x34
#define START_VOLT_B  0x38
#define MOD_ID        0x3C
#define SET_CTRIP_A   0x44
#define SET_CTRIP_B   0x48
#define ushort        unsigned short

```

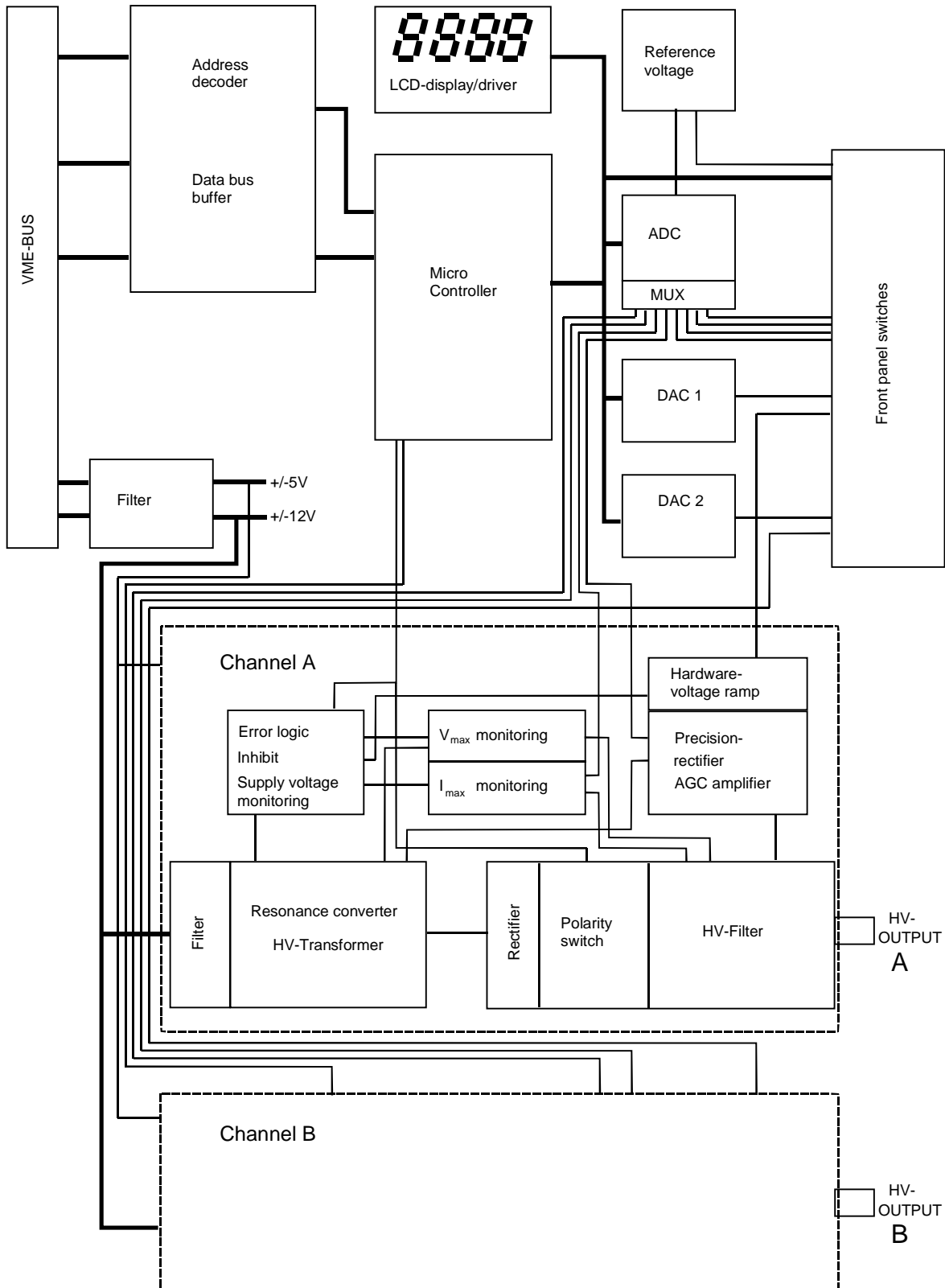

Appendix A: Block diagram VHQ

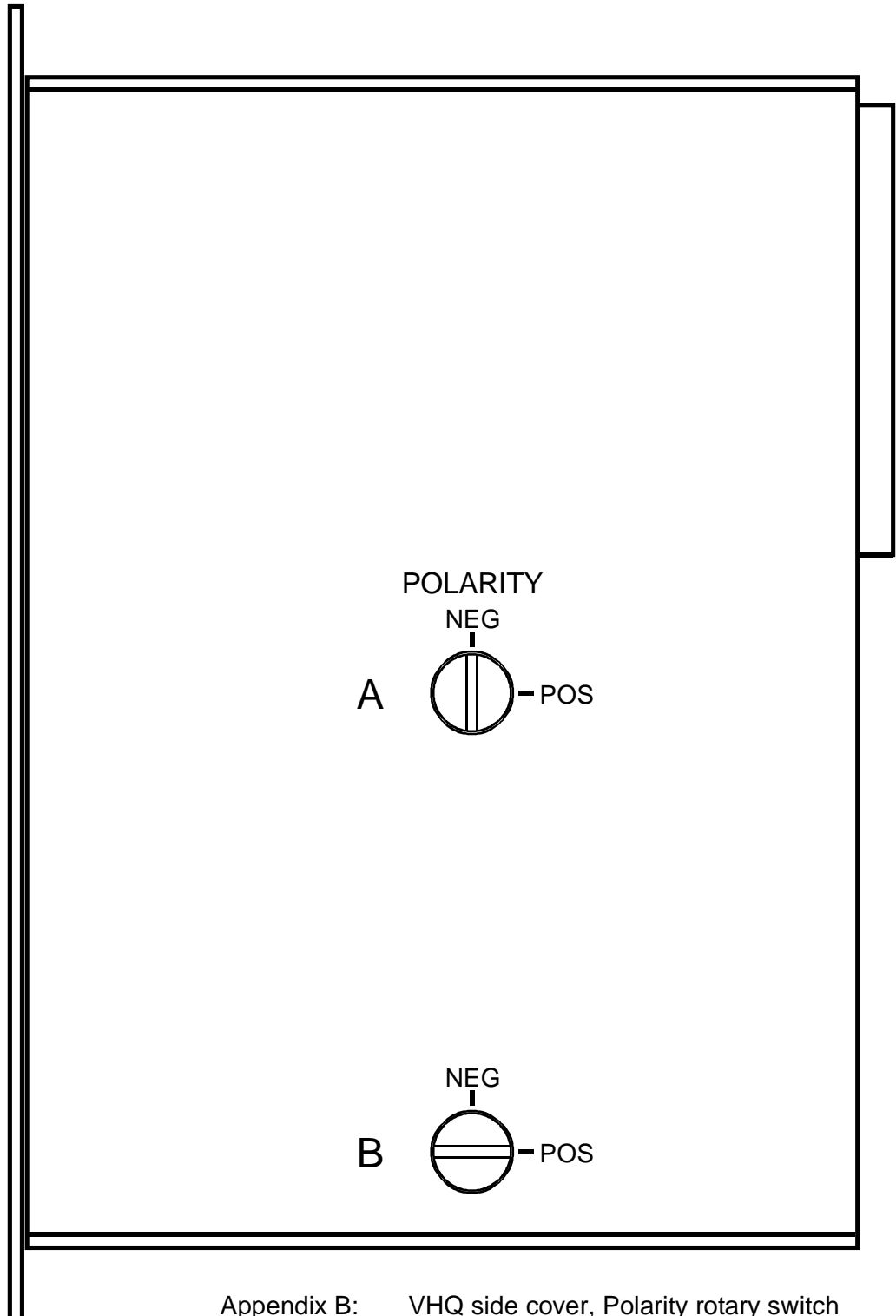

Appendix B: VHQ side cover, Polarity rotary switch  
eg.: channel A - Polarity negative  
channel B - Polarity positive